

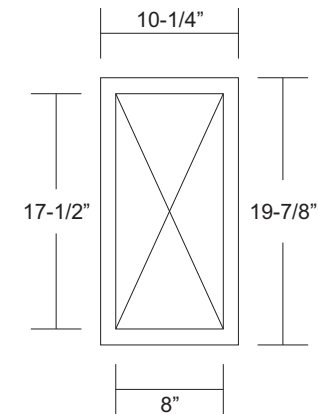

Exhaust Detail

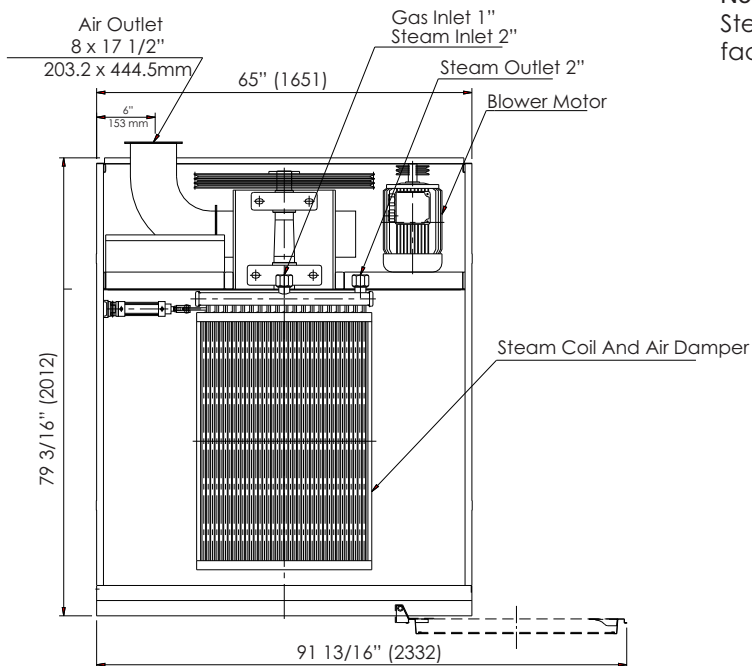

Note:
 Steam Coil / Gas Burner and facia panels are removable to facilitate installation when dealing with low doorways.



DP-200	Units			
	English	Metric		
Cylinder Volume	cu ft	liters	75	2100
Capacity	lbs	kg	200	91
Gas Inlet	inch		1-1/4	
BTU/hr (Gas Heat)			760,000	
Steam Inlet	inch		2	
Steam Return	inch		1-1/4	
Steam Consumption			27 BHP	
Max Steam Pressure	psi	bar	125	9
Airflow (Gas Heat)	CFM	CMM	5,300	150
Airflow (Steam Heat)	CFM	CMM	6,500	184
Max Amps			34	16
Circuit Breaker	208-230VAC	440-460VAC	50	25
Weight	lbs	kg	2535	1149

REV A4	BY AFA	DATE 11-07-17	REV DESCRIPTION Corrected circuit bkr sizing
DRAWN BY A. Adcock		DATE 2-16-2007	 Panama City, FL Phone: 850-249-2222 Fax: 850-249-2226 www.bandctech.com
CHECKED BY C. Oswald		DATE 2-16-2007	
DESCRIPTION General Technical Specifications DP-200			
DATE 2-16-2007	FILE NAME DP-200 Layout.cdr	SHEET 1 OF 1	