

# PS SERIES

## Sheet Folder and Stacker

1, 2, or 4 lane  
with or without crossfolding



### Processes:

- Sheets
- Table Cloths
- Napkins
- Pillowcases
- Flat Goods

The PS Folder and Stacker from B&C Technologies offers high quality construction with a simple design for ease of use. Service is easy - common components are used and our simple design utilizes fewer parts. Fewer parts means less breakdowns and more productivity. The powerful controller is fully programmable and includes built in diagnostics for easy troubleshooting and repair. Easy programming leads to perfect results time after time. The B&C folder can be configured with 1, 2, or 4 lanes with two primary folds and optionally three cross folds. Combine this reliable folder with the labor saving B&C Stacker for greater productivity. The stacker creates stacks of folded goods and the conveyor takes the goods to either the front or the rear of the machine. Simple to operate, built to last and easy to afford.

### Folder / Cross Folder

- ◆ 1, 2, or 4 lane configurations
- ◆ Compact size
- ◆ Inverter driven
- ◆ Static bar
- ◆ 2 primary folds
- ◆ 3 cross folds
- ◆ Self diagnostics
- ◆ Safety controls
- ◆ Bypass all folds
- ◆ Self centering cross fold plate

### Sheet Stacker

- ◆ Belt Drive
- ◆ Easy maintenance access
- ◆ Preset counter
- ◆ Full bypass
- ◆ Electronic measuring

# Technical Specifications:

**Electrical Connection:**  
230V, 3ph, 60Hz, 15A breaker  
460V, 3ph, 60Hz, 15A breaker

**Pneumatic Connection:**  
100 psi / 7 bar  
1/2" / 13mm connection  
5 CFM / 8.5 cubic meters/hr  
8 CFM / 13 cubic meters/hr

**Weight:**  
2800 lbs  
1280 kg

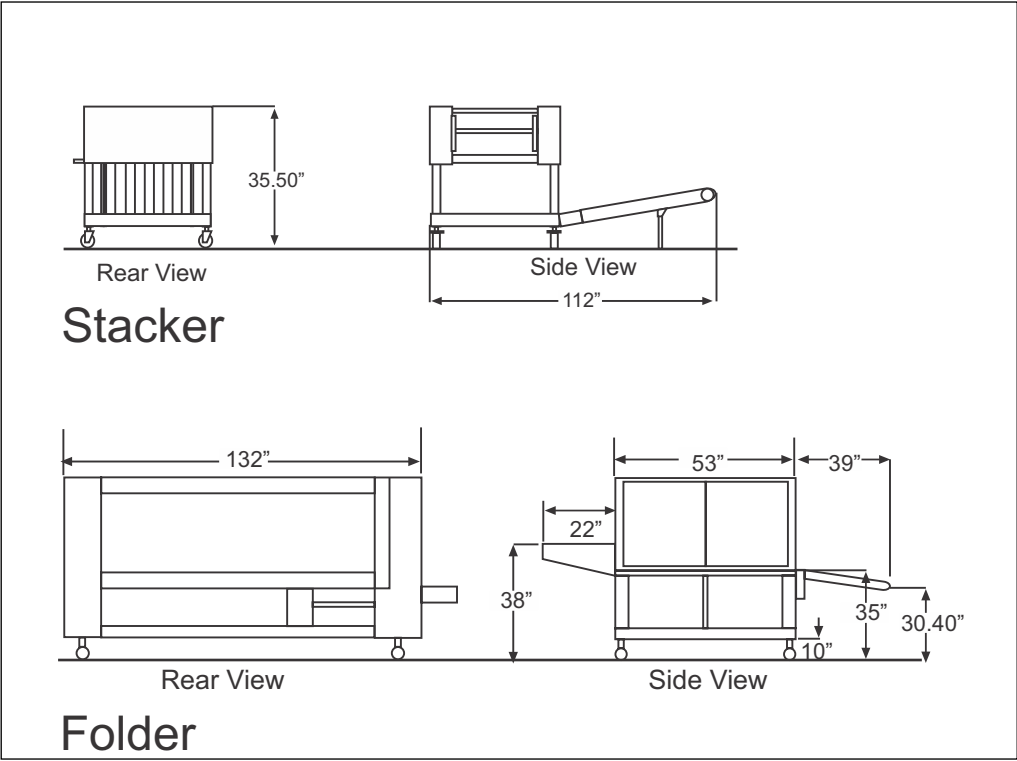

**B&C Technologies**  
1250 West 17th Street  
Panama City, FL 32405  
p: 850-249-2222  
f: 850-249-2226  
www.bandctech.com  
sales@bandctech.com

