

# Ironer

## IS Series Installation and Operation Manual

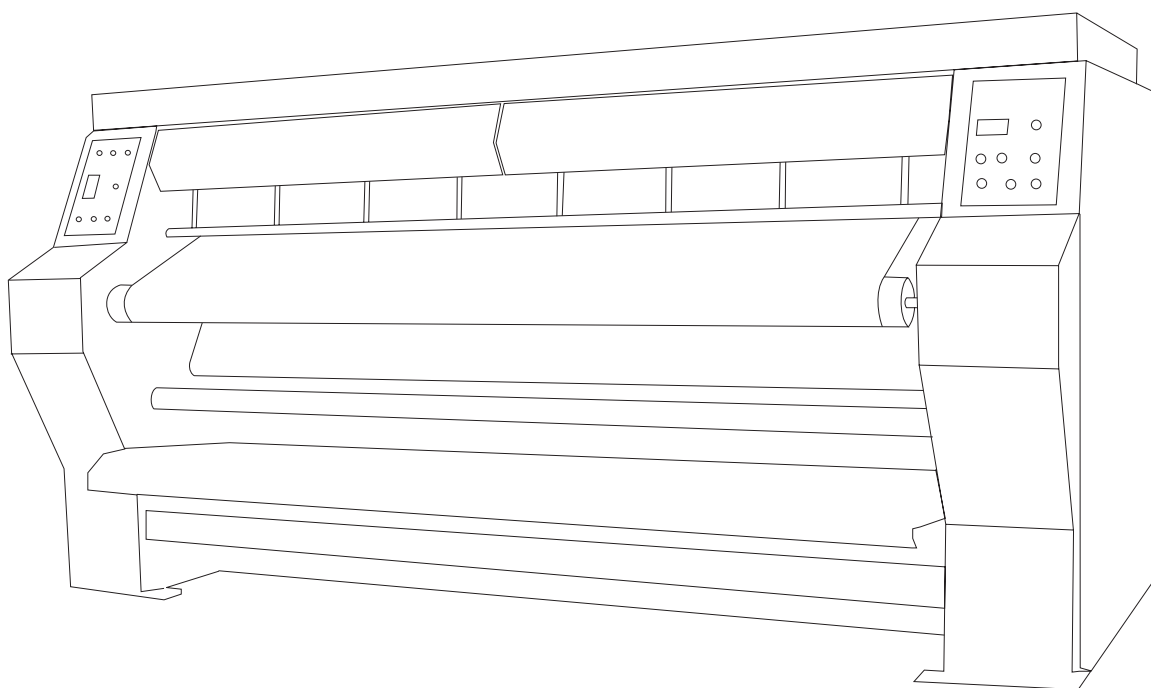

### B&C Technologies

Panama City, FL

(850) 249-2222

(850) 249-2226 FAX

[www.bandctech.com](http://www.bandctech.com)

### Accurate Technologies

Samutprakarn, Thailand

+66 (0) 2740-5511

+66 (0) 2740-5522 FAX

[www.accuratethai.com](http://www.accuratethai.com)

Revision 1.1

06/16/2010



## FOR YOUR SAFETY - CAUTION!

**WARNING:** For your safety the information in this manual must be followed to minimize the risk of fire or explosion or to prevent property damage, personal injury or death.

- ➔ Do not store or use gasoline or other flammable vapors and liquids in the vicinity of this or any other appliance.
- ➔ **WHAT TO DO IF YOU SMELL GAS:**
  - Do not try to light any appliance
  - Do not touch any electrical switch; do not use any phone in your building.
  - Clear the room, building or area of all occupants.
  - Immediately call your gas supplier from a neighbor's phone. Follow the gas supplier's instructions.
  - If you cannot reach your gas supplier, call the fire department.
- ➔ Installation and service must be performed by a qualified installer, service agency or the gas supplier.

Contact your local gas supplier to obtain particular instructions in the event that a user smells gas. Place this sheet and any other instructions obtained from your gas supplier in a prominent location.



# Table of Contents

Ordering Information	6
Model Identification	6
Key Symbols	7
Safety Instructions	9
Receiving Inspection	11
General Specifications	12
Site Requirements	14
Electrical Connections	16
Gas Connection	17
Exhaust Requirements	19
Steam Connections	20
Initial Start Up	21
Controls	22
Operation	24
Troubleshooting	26
Periodic Maintenance	27

## B&C Technologies

Panama City, FL  
(850) 249-2222  
(850) 249-2226 FAX  
[www.bandctech.com](http://www.bandctech.com)

## Accurate Technologies

Samutprakarn, Thailand  
+66 (0) 2740-5511  
+66 (0) 2740-5522 FAX  
[www.accuratethai.com](http://www.accuratethai.com)

# Ironer

## Parts Ordering Information

If you require literature or spare parts, please contact your local distributor. If a local distributor is unavailable, you may contact B&C Technologies directly at (850) 249-2222 for the name of your nearest parts dealer.

For technical assistance in the United States, contact B&C Technologies:

(850) 249-2222 Phone  
(850) 249-2226 FAX  
parts@bandctech.com  
www.bandctech.com

In Thailand:

Phone: +66 (0) 2740-5511  
FAX: +66 (0) 2740-5522  
e-mail: sales@accuratethai.com  
Web: www.accuratethai.com

## Nameplate Location

When contacting B&C Technologies about your equipment, please make note of the model and serial number, located on the nameplate as shown below.

Model #: \_\_\_\_\_

Serial #: \_\_\_\_\_

# Key Symbols

## Safety Information

Anyone operating or servicing this machine must follow the safety rules in this manual. Particular attention must be paid to the DANGER, WARNING, and CAUTION blocks which appear throughout the manual

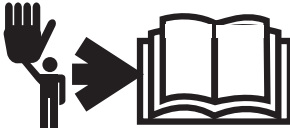
	<b>⚠ WARNING</b>
	<p><b>To prevent serious injury or death, read machine manuals before installing, operating, servicing, or cleaning machine.</b></p>

	<b>⚠ WARNING</b>
	<p><b>Moving parts hazard.</b></p> <p>Can cause serious injury.</p> <p>Do not operate unless all guards and covers are in place.</p> <p>Do not put hands/fingers beyond guard/cover.</p>

 	<b>⚠ WARNING</b>
	<p><b>To prevent serious injury, before service or cleaning:</b></p> <ul style="list-style-type: none"> <li>● Disconnect all utilities such as air, steam, gas and electricity</li> <li>● Release any residual air.</li> <li>● Allow heated parts to cool.</li> </ul>

	<b>⚠ WARNING</b>
	<p><b>Moving parts hazard.</b></p> <p>Can cause serious injury.</p> <p>Do not operate unless all guards and covers are in place.</p> <p>Do not put hands/fingers beyond guard/cover.</p>

	<b>⚠ WARNING</b>
	<p><b>Electrical hazard inside.</b></p> <p>Can cause death or serious injury.</p> <p>Turn off and lockout/tagout all electrical power before opening.</p>

	<b>⚠ CAUTION</b>
	<p><b>Burn hazards.</b></p> <ul style="list-style-type: none"> <li>● Contact with machine components or hot goods can burn you.</li> <li>● Do not operate unless all guards and covers are in place.</li> <li>● Use care when handling recently processed or dried goods.</li> </ul>

# Key Symbols

## Safety Information

	<b>⚠ WARNING</b>
	<p><b>Burn and crush hazards.</b></p> <p>To avoid serious injury, keep hands/fingers, clothing, hair and jewelry away from all hot rolls and moving parts.</p> <p>Before attempting to free jammed flatwork:</p> <ul style="list-style-type: none"><li>● <b>Immediately</b> shut off heat and power.</li><li>● Follow lockout/tagout procedures.</li></ul>

	<b>⚠ WARNING</b>
	<p><b>To prevent serious injury or death:</b></p> <p>Before removing jams, servicing, cleaning, or adjusting equipment, turn off all electrical power and other utilities.</p> <p>Follow lockout/tagout procedures.</p> <p>Do not operate equipment without all guards, belts, and tapes in place.</p>

	<b>⚠ WARNING</b>
	<p><b>Toxic and fire hazards.</b></p> <p>Machine produces gases, fumes and lint which may be toxic or catch fire and could result in serious injury or death.</p> <p>Vent exhaust outdoors and regularly clean lint away from machine.</p>

# Important Instructions

## Safety Information

### Installation Notice:

For personal safety and for proper operation, the machine must be grounded in accordance with state and local codes and in the USA in accordance with the National Electric Code, article 250-96. Elsewhere, the equipment should be grounded in accordance with ANSI/NFPA 70, or the Canadian Electrical Code, CSA C22.1. The ground connection must be to a proven earth ground, not to conduit or water pipes.

Natural Gas or Liquid Propane Gas (LP Gas) heated equipment installation must comply with state and local codes, and in the USA, in accordance with the National Fuel Gas Code. Elsewhere, the equipment should comply with ANSI Z22.1, or CSA B149.

Provisions must be made for adequate make-up air and ventilation, and access for equipment service and installation.

### Installation and Operational Safety Instructions

1. Read all instructions prior to operating this equipment.
2. Ensure that the equipment is properly grounded before applying power and operation commences.
3. Do not process goods that have been previously cleaned in, soaked in, or exposed to gasoline, dry cleaning chemicals, or any other flammable or explosive materials, as they could catch fire or explode without

warning, **even after being washed.**

4. Do not allow children to play in or around or operate this equipment.
5. Check the operation of all safety interlocks at the start of every shift. If the interlocks do not stop the equipment immediately, the machine must be removed from service. Notify your immediate supervisor, and do not operate the machine.
6. Never attempt to service the machine while it is running. Never reach over, under, around, or behind any safety device, or into any area near moving parts or hot surfaces without shutting off power and allowing the machine to adequately cool.
7. Never attempt to remove jammed or misfed goods while the machine is in operation. Attempting to clear jammed goods while the machine is in operation can cause the user to be pulled into the machine, causing serious injury or death. Always stop the machine, remove power, and allow time for cooling before attempting to remove jammed goods.
8. Read, understand, and follow all safety instructions. Do not come close to moving parts and hot surfaces. Do not wear loose clothing, jewelry, neckties, or any other garment that could be caught in the machine while operating or near the machine.
9. Only a qualified technician should attempt to service or repair the ironer.

# Important Instructions

## Safety Information

10. Do not install the machine in an area where it could be exposed to water or weather.
11. Do not alter or tamper with the control system.
12. To reduce the risk of fire, do not process plastics or articles containing foam rubber or similarly textured rubber-like materials.
13. Keep the area near the exhaust ducting clean and free of lint, dust, dirt or debris.
14. Keep the interior and exterior of the machine clean of lint, dirt, dust and debris. The interior of the machine, along with the exhaust ductwork should be periodically inspected and cleaned to avoid potential fires (lint is highly flammable).
15. Improper installation, operation and maintenance of this machine can cause exposure to substances in the fuel or from combustion that can cause serious illness or death.
16. Always disconnect the electrical service from the machine and allow it to cool before performing service.
17. This machine must be installed according to the installation instructions. All electrical connections, and gas or steam connections must comply with state and local codes and must be made by a licensed installer where required.

# Installation

## Receiving Inspection

Upon receipt of the equipment, visually inspect for shipping damage and note any damage with the carrier before signing the shipping receipt, or advise the carrier of the damage as soon as it is noted.

If damage is discovered, a written claim must be filed with the carrier as soon as possible.

**Note: Warranty is VOID unless the equipment is installed according to instructions. The installation must comply with the minimum requirements listed in this manual. All national, state and local codes must be followed including but not limited to gas, electrical, plumbing and HVAC. Due to various requirements, statutory codes should be well understood before installation commences.**

# Installation

## General Specifications and Utility Connection Points

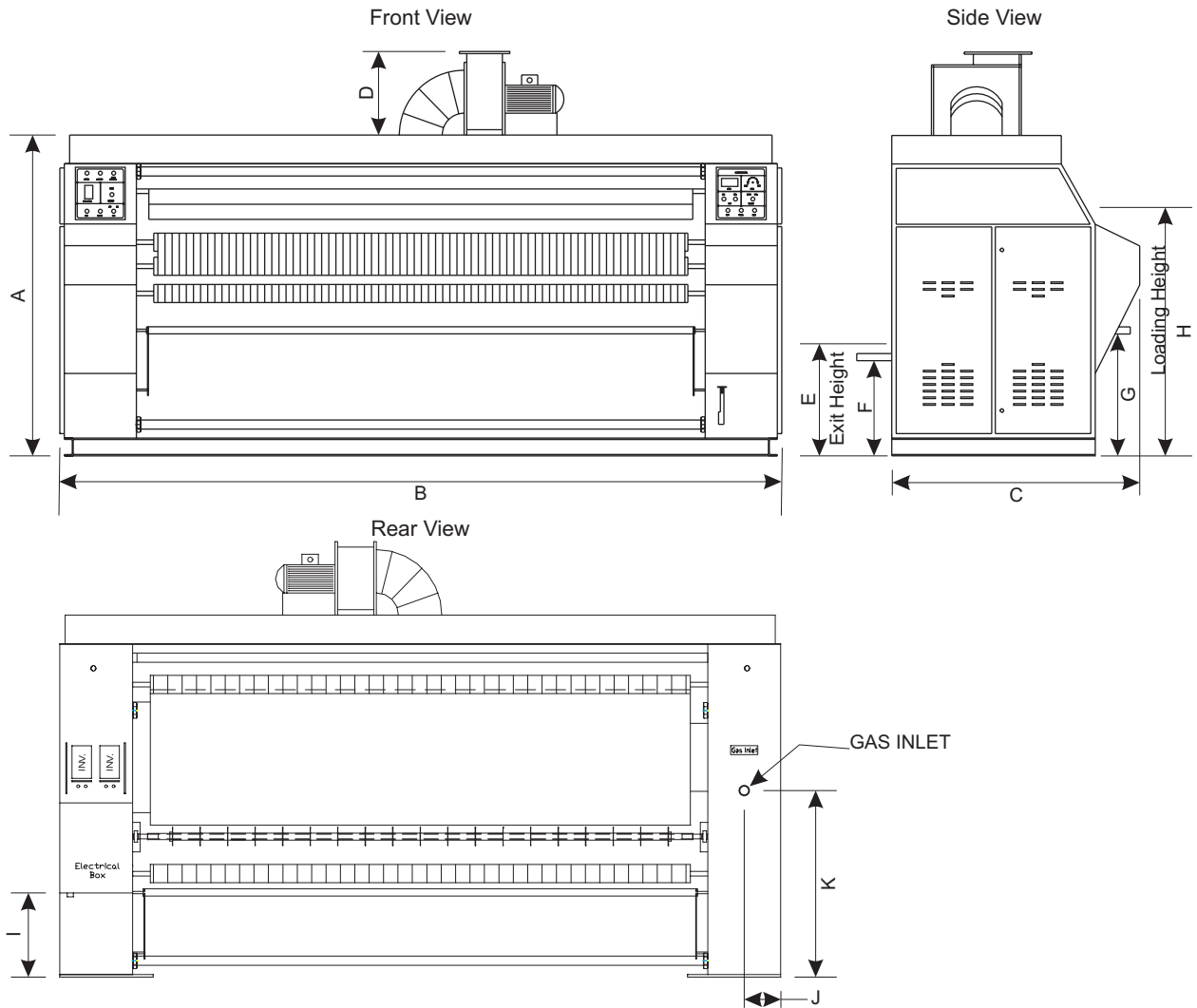

Dimension	IS-14120		IS-18120		IS-24120		IS-32120	
	inch	mm	inch	mm	inch	mm	inch	mm
A								
B								
C								
D								
E								
F								
G								
H								
I								

# Installation

General Specifications										
Model			IS-14120		IS-18120		SI-24120		IS-32120	
	Metric	US								
Number of Rolls			1		1		1		1	
Roll Diameter	mm	inch	356	14	457	18	610	24	813	32
Working Width	mm	inch	3048	120	3048	120	3048	120	3048	120
Speed Range	m/min	ft/min	2.5-11	8-36	2.5-14	8-45	3.75-22	12-75	4.5-30	15-98
Dimensions										
Width	mm	inch	4056	159.69	4056	159.69	4056	159.69	4056	159.69
Depth	mm	inch	820	32.28	855	33.66	1156	45.51	1582	62.28
Height	mm	inch	1920	75.59	2195	86.42	2325	91.54	2500	98.43
Canopy Height	mm	inch	340	13.39	500	19.69	500	19.69	500	19.69
Exhaust System										
Air Flow	cmm	cfm	30.5	1080	50	1765	50	1765	50	1765
Exhaust Duct	mm	inch	228.6	9	254	10	254	10	254	10
Drive Information										
Drive Motor	kW	HP	0.75	1	0.75	1	1.1	1.5	2.2	3
Delivery Motor	kW	HP	0.25	1/3	0.25	1/3	0.25	1/3	0.25	1/3
Blower Motor	kW	HP	0.75	1	1.5	2	1.5	2	1.5	2
Steam										
Consumption	BHP		3.8		4.4		6		8	
Pressure	bar	psi	6.3-8.8	90-125	6.3-8.8	90-125	6.3-8.8	90-125	6.3-8.8	90-125
Inlet Size	mm	inch	19.1	0.75	19.1	0.75	25.4	1	31.8	1-1/4
Outlet Size	mm	inch	12.7	0.5	12.7	0.5	19.1	0.75	25.4	1
Gas										
Heat Input	BTU		260,000		285,000		620,000		825,000	
Gas Inlet Size	mm	inch	12.7	0.5	25.4	1	25.4	1	25.4	1
Weight & Shipping										
Net Weight	kg	lbs	1140	2508	1730	3806	2180	4796	2500	5500
Shipping Weight	kg	lbs	1290	2838	1910	4202	2390	5258	2740	6028

Specification and Design subject to change without notice

# Installation

## Site Requirements

### Service Clearance

The figure below shows the recommended minimum service clearances. The dimensions shown are needed to adequately service and operate the machine with maximum efficiency. Reducing this clearance is not recommended. You must allow space around the machine for maintenance.

### Floor Requirements

The installation site must have flooring capable of supporting the weight of the machine without flexing. Consult the general specifications in the previous section for specific details on the machine's weight and other technical specifications. No special foundation, grouting, or anchoring is required by the manufacturer, but some shimming may be required so that the

machine is completely level. Always follow local codes when performing a machinery installation. It is the responsibility of the installer to be familiar with the requirements of local codes.

### Gas Requirements

The ironer requires a significant gas service capable of providing the volume and pressure needed to achieve the BTU rating of the particular machine. Typical gas pressure ranges from 12 inches water column to 2 PSI with ratings up to 825,000 BTU. Refer to the previous section for gas connection sizing, gas pressure requirements and BTU ratings.

### Exhaust Duct Requirements

A short run of exhaust vent ducting is required and must be procured locally.

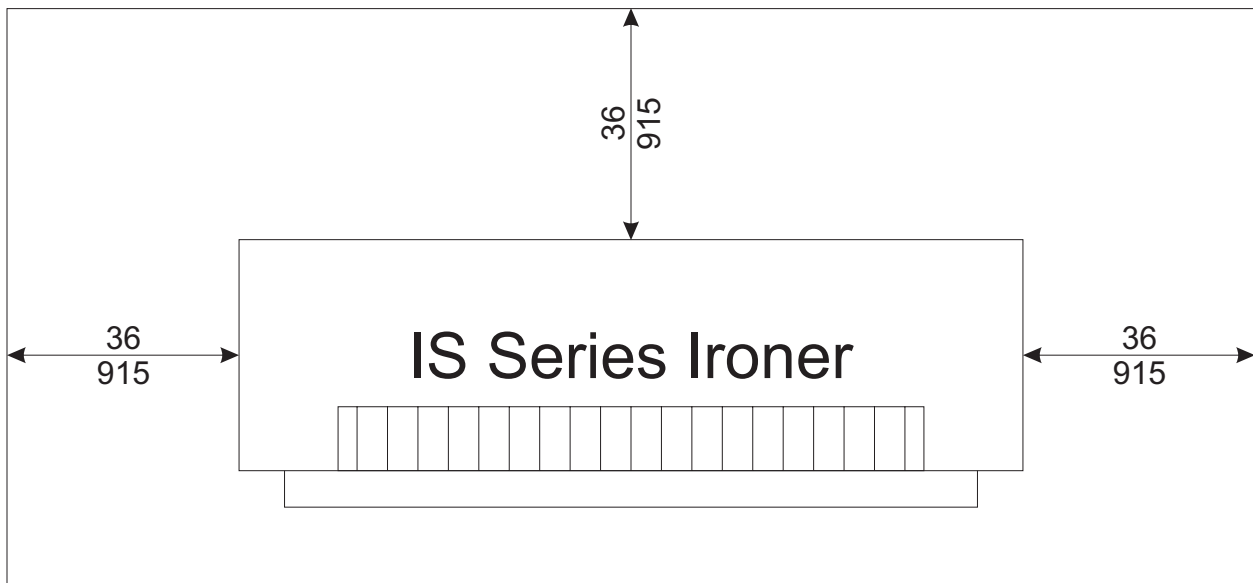

# Installation

## Site Requirements

Adequate ventilation is required and must meet all local codes. Refer to the previous section for airflows and other pertinent information.

**Important: Do not interrupt the flow of make-up air or the exhaust!**

Use the shortest possible path with the fewest number of bends to connect to the outlet ductwork. Measured backpressure should not exceed 0.3 inches of water column pressure for reliable ignition and best results.

**Note: Check for proper exhaust fan rotation direction before placing the equipment into service. If the rotation is incorrect, remove power from the machine and exchange any two incoming power leads.**

### Electrical Requirements

Pay attention to the nameplate of the machine - it contains the specific electrical requirements of the machine. Additional requirements can be found in the previous section.

Note! Do not use phase adders (roto-phase) on inverter driven equipment!

The machine should be connected to an individual branch circuit not shared with lighting or other equipment.

A lockable, load break rated, visible break disconnect switch with safe working

clearances is required for all installations. A disconnect plug is also acceptable, so long as it is able to safely break the load, is in an accessible location, and can be locked.

The connection should be shielded in a liquid tight or approved flexible conduit with proper conductor of correct size installed in accordance with National Electric Code (USA) or other applicable codes. The connection must be made by a qualified electrician using the wiring diagram provided with the machine.

For personal safety and for proper operation, the machine must be grounded in accordance with state and local codes and in the USA in accordance with the National Electric Code, article 250-96.

The ground connection must be to a proven earth ground, not to conduit or water pipes.

Do not connect the ground to the neutral (N) leg at the terminal strip.

If a DELTA supply system is used, the high leg should be connected to T or L3, as control power is derived from L1 & L2.

# Installation

## Electrical Connection

Electrical connections should be made by a qualified electrician in accordance with all applicable codes or requirements. Use a separate branch circuit to power each machine. Do not share circuits with lighting or any other equipment.

A shielded liquid tight or approved flexible conduit with proper conductor of correct size installed in accordance with National Electric Code (USA) or other applicable codes is required. The connection must be made by a qualified electrician using the wiring diagram provided with the machine.

For personal safety and for proper operation, the machine must be grounded

in accordance with state and local codes and in the USA in accordance with the National Electric Code, article 250-96. The ground connection must be to a proven earth ground, not to conduit or water pipes.

Do not connect the ground to the neutral (N) leg at the terminal strip (if so equipped).

If a DELTA supply system is used, the high leg should be connected to L3, since control voltage is derived from L1 and L2.

Insure that the control transformer taps are connected in accordance with the incoming line voltage. Verify connections as shown on the schematic with each machine.

## Gas/Steam Heat Models

Rating	Model	Amps	Breaker
208-230V, 50/60Hz	IS-14120	8A, 3ph	15
	IS-18120	10A, 3ph	15
	IS-24120	12A, 3ph	15
	IS-32120	16A, 3ph	20
380-480V, 50/60Hz	IS-14120	4A, 3ph	15
	IS-18120	5A, 3ph	15
	IS-24120	6A, 3ph	15
	IS-32120	8A, 3ph	15

# Installation

## Gas Connection

### Gas Supply Line

- 1" IPS pipe is recommended.
- 1" approved tubing is acceptable for lengths under 25 ft (6.1 m) if local codes and gas supplier permit.
- Must include 1/8" NPT minimum plugged tapping accessible for test gauge connection, immediately upstream of the gas connection to the ironer (see illustration).
- Must include a shutoff valve:

An individual manual shutoff valve must be installed within 6 feet (1.8m) of the equipment in accordance with the National Fuel Gas Code, ANSI Z223.1. The location should be easy to reach for opening and closing.

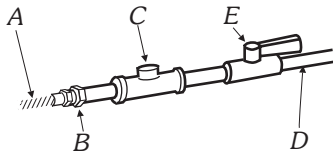

- A. 1" flexible gas connector
- B. 1" pipe to flare adapter fitting
- C. 1/8" NPT plugged tapping
- D. 1" NPT gas supply line
- E. Gas shutoff valve

### Gas Supply Connection Requirements

There are many methods by which the IS series Ironer can be connected to the gas supply. Following are some guidelines for methods of connection.

#### Option 1:

Flexible stainless steel gas connector:

If local codes permit, use a new flexible stainless steel connector (Design certified by the American Gas Association or CSA International) to connect between the ironer and the gas supply line. Use an elbow and a 1" flare x 1" NPT adapter fitting between the stainless steel gas connector and the gas inlet of the machine as needed to prevent kinking.

#### Option 2

Other approved piping:

- Lengths under 25 feet (6.1m) use 1" approved tubing.
- Lengths over 25 feet (6.1m) should use larger piping.
- Pipe joint compounds that resist the action of gas must be used. **DO NOT USE TEFLON®/PTFE TAPE.**

**IMPORTANT:** Be certain the ironer is configured for the type of gas being used. The gas type is shown on the serial sticker on the electrical panel of the unit.

### Inlet Pressure

Use a manometer to verify that the inlet pressure meets the following requirements:

Natural Gas service must be supplied at 4-14 inches of water column pressure.

LP Gas service must be supplied at 11-14 inches of water column pressure.

# Installation

## Gas Connection

### Manifold Pressure

Be sure to check the manifold pressure. Use a manometer to verify that the manifold pressure matches the information on the serial sticker and the type of gas being used. A separate gas regulator (locally obtained) must be installed if the incoming line pressure is greater than 14 inches water column pressure.

1. Connect the manometer to the pressure connection on the gas valve (disconnect gas service).
2. Restore gas service, and determine the pressure while the burner is ignited. The pressure must match the indicated manifold pressure on the serial sticker.

### Gas Conversion

Notice: Do not connect a machine configured for Natural Gas to LP Gas service or vice-versa without a qualified service technician doing a proper conversion. After the reconfiguration is complete, the manifold pressure must be verified and the combustion air valve must be adjusted for proper operation.

# Installation

## Exhaust Requirements

	<b>⚠ WARNING</b>
	<b>Toxic and fire hazards.</b> Machine produces gases, fumes and lint which may be toxic or catch fire and could result in serious injury or death.  Vent exhaust outdoors and regularly clean lint away from machine.

For best results, install the ironer near an outside wall in order to keep the exhaust duct length as short as possible, and to provide a source of make-up air. Neither the rear nor the sides of the ironer should be blocked. Blocking the air inlets prevents proper combustion, and will yield poor results, and possibly harmful combustion byproducts.

**Important: Do not interrupt the flow of make-up air or the exhaust!**

Use the shortest possible path with the fewest number of bends to connect to the outlet ductwork. Measured backpressure should not exceed 0.3 inches of water column pressure for reliable ignition and best results.

**Important: Under no circumstance should this ductwork be shared with other equipment.**

**Note: Check for proper exhaust fan rotation direction before placing the equipment into service. If the rotation is incorrect, remove power from the machine and exchange any two incoming power leads.**

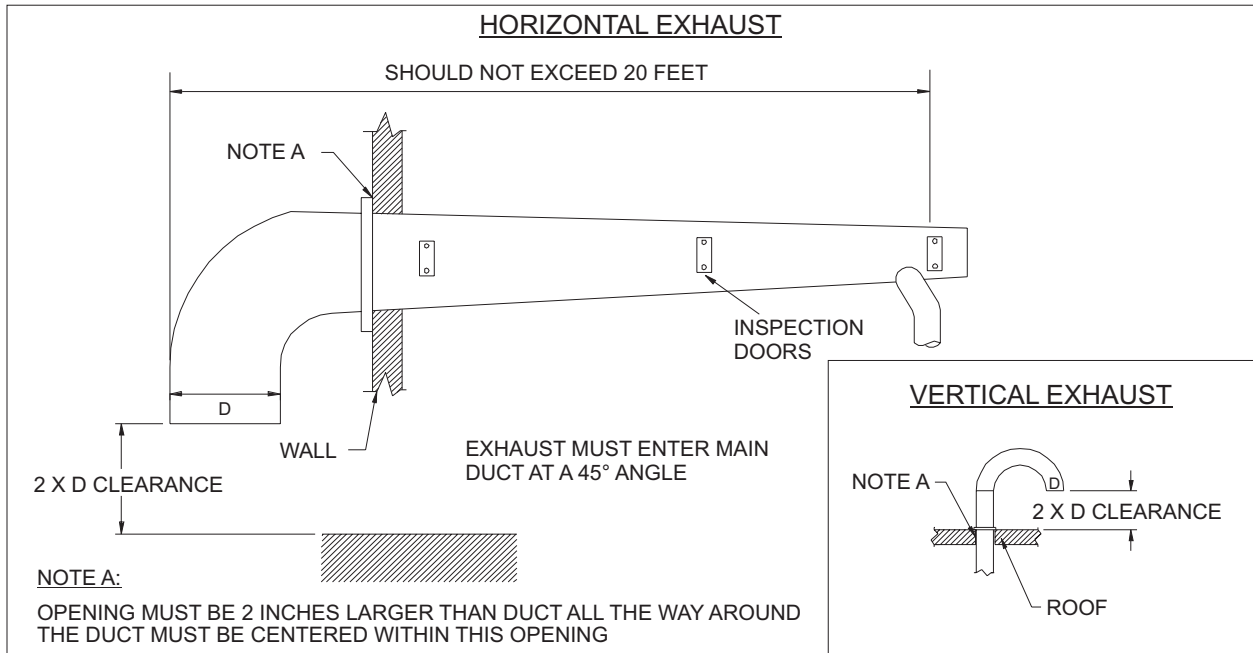

# Installation

## Steam Connections

For best results, operate with a steam pressure of 90-125 psi (6.2-8.6 bar). The steam inlet and return are located on the rear of the machine. The inlet is marked as such and is 3/4" NPT (IS-14120), 1" NPT (IS-18120 & IS-24120) or 1-1/4" NPT (IS-32120). The return is marked as such and is 1/2" NPT (IS-14120 & IS-18120), or 3/4" NPT (IS-24120), or 1" NPT (IS-32120).

Important: Insulate all steam and return lines for the safety of the operator and service technician.

Important: All steam components must be rated for a minimum of 200 psi (14 bar) working pressure. Shut off valves must be installed upstream of the steam inlet, and downstream of the steam trap so that the equipment can be isolated for maintenance or emergency.

Important: Support all steam lines and components to minimize the load on the steam connections to the ironer.

Obtain steam service piping from a steam system supplier or a qualified steam fitter.

Use a minimum of 12 inch (300mm) rise above the header to prevent condensate from draining into the ironer. Do not make a steam connection to the header with a horizontal/downward facing tee or elbow.

Wherever possible, horizontal runs of steam lines must gravity drain to the steam header. Water pockets or improperly drained

headers will yield poor results due to wet steam.

Install a union and valve in the steam supply and return lines for ease of service.

Install an inverted bucket trap with strainer and a check valve. For best results, install the trap at least 18 inches (450mm) below the inlet and as close to the machine as possible. Install the trap according to the instructions with the unit, noting the steam flow direction. If the steam is gravity returned to the boiler, install a vacuum breaker and check valve in the return line near the machine. Note that all return plumbing must be below the return inlet.

To prevent eventual water hammer, route all return lines below steam outlets.

# Installation

## Initial Start Up

Before operating the ironer, check the following:

1. Check that the machine is level and in a stable position on the floor. The machine should not rock or move in any way.
2. Ensure that all electrical, gas/steam, and exhaust connections are made and leak free.
3. Check that the ironer is correctly grounded according to the earlier listed specifications (see page 8).
4. Remove all packaging and protective shipping materials. Discard these items - do not store them near the ironer.
5. Inspect the thermostat sled assembly and make sure it is in full contact with the ironing cylinder, and is free of lint and debris.
6. Turn the heating control to the OFF position, and the speed control to minimum (fully counter-clockwise).
7. Apply power to the machine. Before doing this, double check that the supply voltage matches the information on the serial sticker of the ironer.
8. Press the green START button.
9. Double check that the exhaust fan is rotating in the direction indicated on the

blower housing. Additional information can be found on page 17.

10. Make sure the feeding belts are acting to pull linen into the machine (belts traveling towards the heated cylinder)
11. Replace all panels. **DO NOT DEFEAT INTERLOCK SWITCHES!**
12. For gas units, move the heat switch to the ON position. The heat light turns on. There will be a delay of 30 seconds prior to ignition.
13. Check that the temperature increases. When the temperature reaches the set point, the heat light should turn off.
14. Use old or worn linen to perform the initial ironing test.
15. Lay the linen on the feeding belts and allow it to be pulled into the ironer.
16. Adjust the speed control so that the goods come out of the ironer dry and finely pressed.

# Operation

## Controls

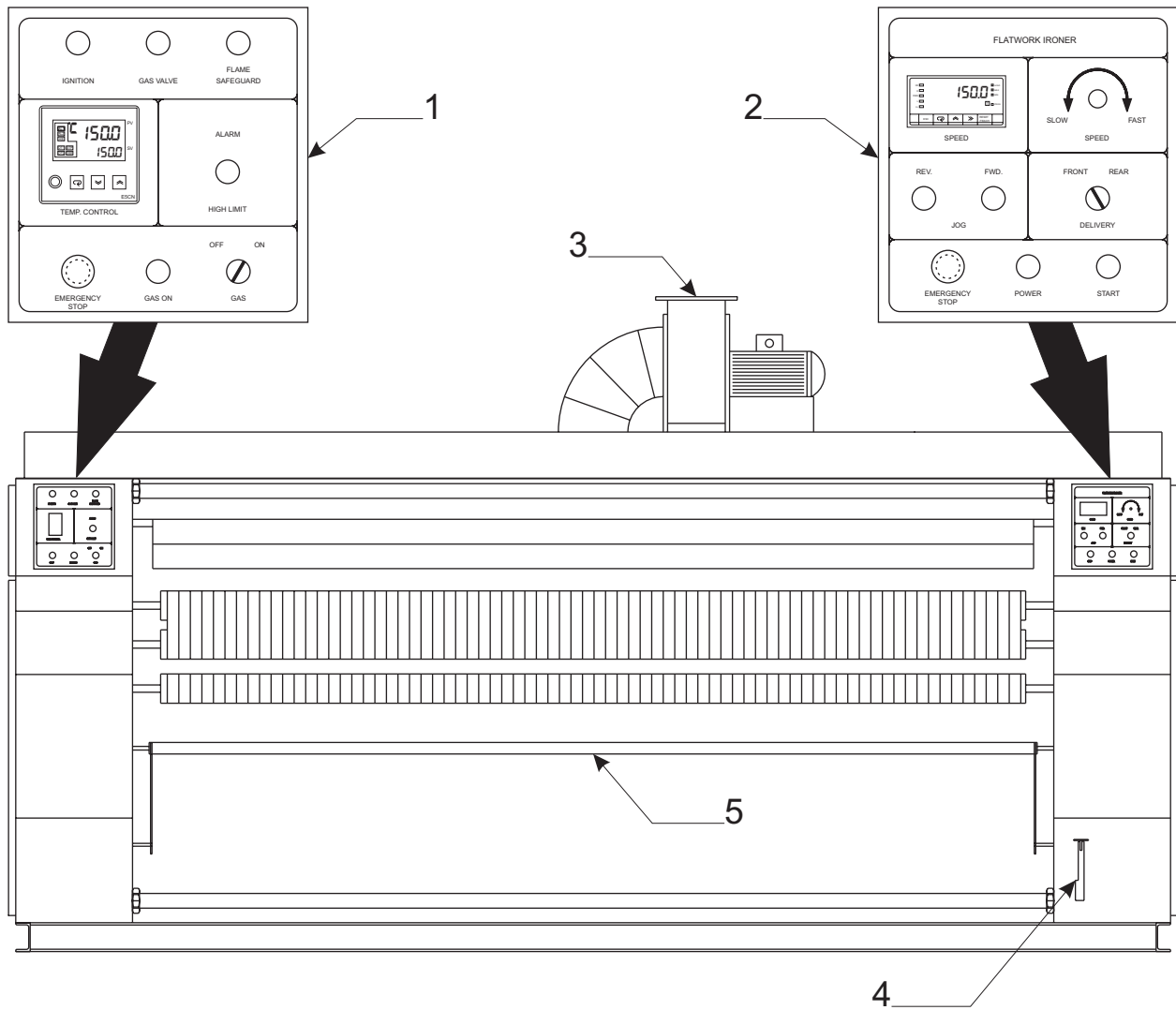

1 - Heating Control Panel (see description, next page)

5 - Front Return table

2 - Speed Control Panel (see description, next page)

3 - Exhaust

4 - Compression roll release

# Operation

## Controls

### Heating Control Panel

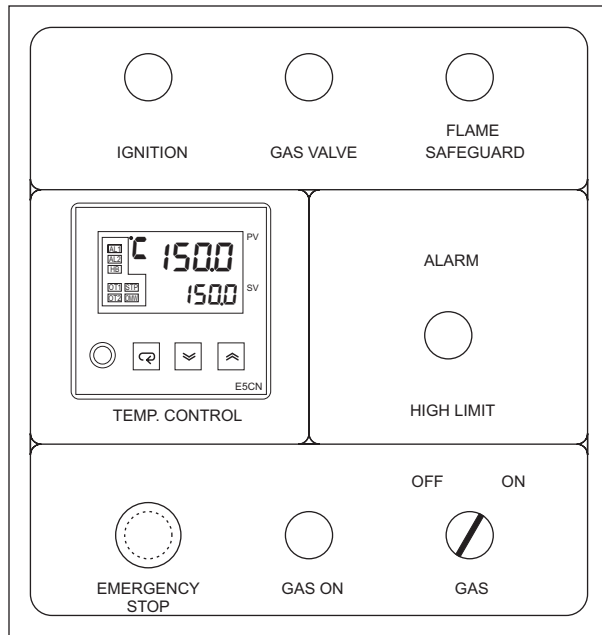

### Speed Control Panel

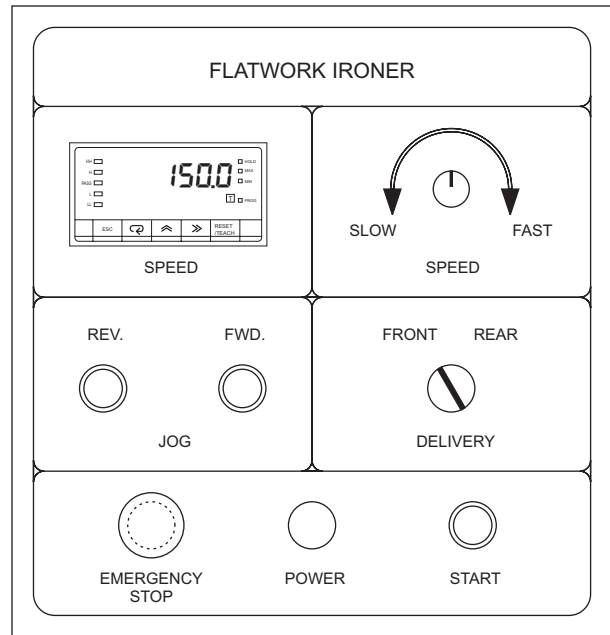

Ignition - Indicates a call for heat

Gas Valve - Indicates the gas valve is open, and machine is heating.

Flame Safeguard - Will briefly illuminate upon call for heat. Continuous illumination indicates ignition failure.

Temperature Control - Sets operating point of machine. Press the up arrow to increase the operating temperature and the down arrow to decrease the operating temperature.

Alarm High Limit - Safety thermostat has been activated. Check for proper operation of temperature control.

Emergency Stop - Press to stop machine in case of an emergency. Pressing while machine is in operation and temperature is above 70°C (158°F) can cause damage to the machine.

Gas On - illuminates when the Gas switch is in the on position.

Speed - indicates actual speed in feet/minute of the ironer, can also be set to display in meters/minute. Contact the factory for details.

Speed knob - Rotate clockwise for increased speed, counter-clockwise for slower speeds.

Jog - press and hold to jog machine forwards or backwards to remove caught goods.

Delivery - set switch to Front to return the finished goods to the front of the machine; set to Rear for rear return.

Emergency Stop - Press to stop machine in case of an emergency. Pressing while machine is in operation and temperature is above 70°C (158°F) can cause damage to the machine.

Power - Indicates that the machine is ready to run

Start - Press and hold for 1-2 seconds to start machine. Make sure the Emergency Stop buttons are released.

# Operation

## Procedure

Notice: Do not perform maintenance on this machine while it is running, the cylinder is hot, or while the machine's circuit breaker is on.

Prior to starting the first shift of the day:

1. Inspect the area between the thermostat sled and the ironing cylinder. Gently lift the pick up sled away from the cylinder.
2. Clean any debris found away from the pick up sled and cylinder.
3. Ensure that the pick up sled remains in contact with the ironing cylinder.

To Operate Ironer:

1. Be familiar with the controls - see diagram on the previous page.
2. Turn the heat control to the OFF position (Gas models only), and rotate the speed control to the minimum (counter-clockwise) position.
3. Press the green start button for 1-2 seconds.
4. Ensure that the feed belts rotate towards the ironing cylinder.
5. Verify that the finger/hand guard safety panel immediately stops the

ironer when pressed. If the ironer does not stop, discontinue use and follow all lock out/tag out procedures and call a qualified service technician.

6. Restart the ironer by pressing the green start button for 1-2 seconds.

**IMPORTANT: For steam heated machines, open the steam supply valve VERY SLOWLY to avoid damage to the rotating steam joint.**

Steps 7 & 8 are for gas heated models only

7. Turn the heat switch to the ON position. After 30 seconds, heating will begin. The temperature indicator on the temperature control should indicate increasing temperature. The set temperature is factory programmed to 150 °C (302 °F).

8. The heat indicator lamp will go out once the set temperature is reached.

9. Place linen on the feed table, allowing the feed belts to automatically pull the goods into the ironer.

NOTE: When ironing small goods such as pillow cases, work from left to right along the length of the ironer. This will provide optimum results - running small goods in "lanes" will result in cool spots on the cylinder and poor ironing performance, and could damage the feeding and return belts. See the diagram on the next page.

# Operation

## Procedure

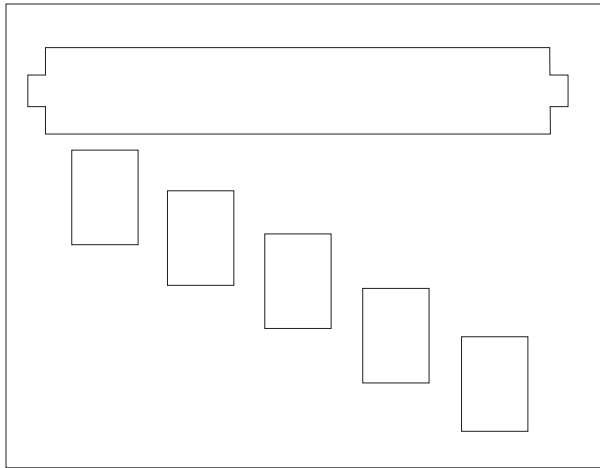

Proper feeding of small goods.

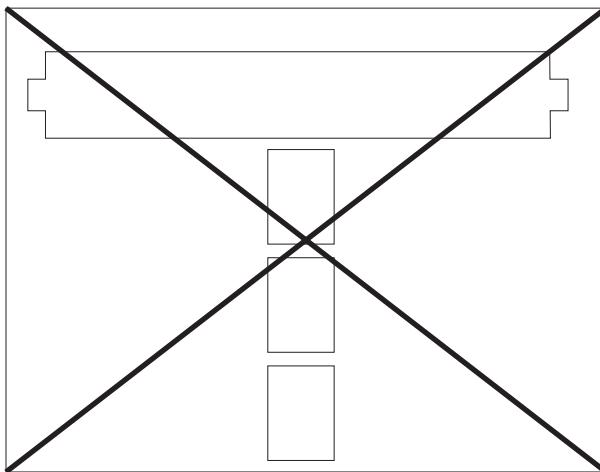

Improper feeding of small goods.

speed according to the weight and residual moisture of the goods. Obviously, thicker, wetter goods will require slower speeds than thinner, dryer goods.

11. Remove the finished goods from the output table, and fold or hang goods to prevent wrinkling.

12. To shut down the ironer at the end of the day, turn the heat switch to the OFF position, and allow the ironer to cool down to 70 °C (158 °F) before pressing the red stop button to power down the ironer.

### For Best Finish Results:

☞ The pH of the goods to be ironed must be between 5.5 and 6.5.

☞ Do not use fabric softener! Fabric softener will be deposited onto the feeding belts and ironing cylinder causing poor performance and maintenance problems.

10. Turn the speed control clockwise to increase the speed, or counter-clockwise to decrease the speed. Slower speeds should be used if the goods are not exiting the ironer fully dry. Adjust the

# Basic Troubleshooting

## Procedure

### Temperature Control shows 5Err

Indicates an input error. Check the input wiring for bad connections and short-circuits.

### Temperature Control shows E!!!

Indicates a memory error. Turn the machine power off, then back on. If the display continues to show the error, contact a qualified service technician.

### Temperature Control shows cccc or bbbb

Damaged sensor or wiring. Repair or replace.

### Speed Display shows n!Err, n2Err, n3Err, Err-a, or chG-a

Indicates a memory error. Turn the machine power off, then back on. If the display continues to show the error, contact a qualified service technician.

### Ironer will not start or stops suddenly

-Make sure the Emergency Stop button isn't pressed.

-Check the hand/finger guard.

-Check that all panels are in place and attached.

### Ironer makes unusual noises

If the ironer makes unusual noises (rubbing, grinding, banging, etc.) properly shutdown the machine and contact a qualified service technician. Remember to follow all lock-out/tag-out procedures.

# Periodic Maintenance

## Procedure

### Daily

Inspect the temperature pick up sled and the cylinder. Remove debris if present.

Make sure the temperature pick up sled is in full contact with the ironing cylinder.

At shut down, wipe machine down with a mild cleaning agent and vacuum or sweep up any lint that has accumulated. Lint is highly flammable!

### Weekly

Grease all bearings with high temperature polyurea grease. DO NOT mix different grease types.

Inspect safety labels and replace any that are damaged, worn, or illegible.

Inspect the guide ribbons (guide tape) for damaged or missing ribbons. Replace as necessary.

Remove lint from the combustion blower intake filter located on the left end under the cylinder.

### Monthly

Inspect feed belts for proper tension. There should be no slippage as the ironer runs. Do not over tighten the feed belts, as this will cause premature wear.

Inspect the return belts for proper tension. Return belts tend to elongate after initial startup and wear in.

Inspect and lubricate the drive chain and gears.

Inspect the compression roll and ensure that the pressure is correct. The compression roll should only slightly touch the ironing cylinder and not exert too much pressure.

For steam models, inspect the rotary steam joint for leaks. If a leak is noted, a repair kit is available. Refer to the parts manual for details.

**Caution: DO NOT touch or get too close to the steam piping. EXTREMELY HOT!**

Clean the exhaust system, including blower and ductwork.

Clean the AC drive cooling fan and heat sink, located on the underside of the drive.

Clean the ironing cylinder, removing any residue.

Clean the steam trap filter (obviously, steam models only.). See diagram for typical trap.

1. Turn off steam supply and allow time for the valve to cool if necessary.
2. Unscrew nut.
3. Remove element and clean.
4. Replace element and nut.

