



B&C

Technologies

Product Catalog

Professional Laundry
Equipment

B&C Technologies
Panama City, Florida
Phone: 850-249-2222
Fax: 850-249-2226
Web: www.bandctech.com
Email: sales@bandctech.com





We started B&C Technologies with one goal in mind. To provide the highest quality laundry equipment at an affordable price. We started out with less than 10 machines and since that time we have worked hard to offer the largest variety of equipment to meet most laundry needs. Now with over 100 different products available we are the laundry solution. We strive to continue to be pioneers with our innovative products and technologies that have helped us to become industry leaders.

In addition to the high standards we have set for our equipment, we have also set those same high standards for ourselves. We have built a foundation on innovation, dependability, and a set of solid values that have guided us and allowed us to build a strong, talented team. We are excited about the future growth of B&C Technologies as we strengthen our industry position. As we continue to grow we will maintain the family atmosphere and close, personal relationships that set us apart. Welcome to the B&C family.

Pictured above, the B&C Technologies ownership families. Seated, left to right: Mats Bruce, Catharina Whitehead, Bengt Bruce. Standing, left to right: Gary Cowen, Bob Cowen, Bobby Cowen.

Table of Contents

Your Single Source	4
Washer-Extractors	5
HE Series	6
HP Series	7
SP Series	8
SI Series	9
SA Series	10
SB Series	11
Water Washing	12
Ozone Systems	13
Dryers	14
DE Series	15
DP Series	16
DI Series	17
Drying Cabinets	18
TS-63	19
TS-93	20
FC-20	21
Ironers	22
IP Series	23
IS Series	24
IQ Series	25
IF Series	26
IM Series	27
Feeding and Folding	28
PF Series	29
PS Series	30
Product Testimonials	31
Industries Served	32
Service/Hospitality	33
Firehouse	34
Healthcare	35
Dairy/Agriculture	36
Athletics	37
Drycleaning	38
Commercial Laundry	39
Industrial Laundry	40
Carwash	41
Accounting & Office	42
Engineering	43
Parts & Service	44
Production Team	45
Sales & Marketing	46
The B&C Family	47



One Single Source One Comprehensive Line

Built to last. That's the first requirement for any B&C machine. Add affordability, reliability and the highest quality components and you have the foundation of this industry leader. Our machines are engineered and tested to withstand the most rigorous demands of any laundry. We know that exceeding industry standards doesn't have to be expensive - that's why we offer a high end product with a low cost of ownership. Affordability meets durability.

Engineering Driven

Our experienced staff of engineers is available to help make sure that your next project is a success. With our extensive experience in the industry, we can assist you in choosing the appropriate equipment for your specific need. Best of all, this experience is only a phone call away. When you call us you will immediately speak with someone that can help you. No more endless circles and wasted time caught in someone's voicemail system.

Customer Focused

The dynamics of a family owned company differ widely from the run of the mill corporate companies that are so common. We understand the importance of personalized service. We value our customers and strive to provide unsurpassed customer service. At B&C we make it our business to look out for your business.

B&C offers the lowest cost of ownership while maintaining the highest industry standards. Call or visit us online www.bandctech.com to see how you can benefit from the most dependable line of equipment offered in the industry.



The Washer-Extractor Line From B&C Technologies

Outstanding Reliability and Efficiency at an Affordable Price

The B&C Technologies line of washer-extractors are designed to be effortless and powerful while maintaining a low cost of ownership. Our entire line saves you money over the life of the machine. In addition to a low initial investment, our machines have fewer parts. Fewer parts mean fewer things to break, which leads to less down time for the equipment and fewer repairs.

Higher extraction equals less time in the dryer which reduces energy consumption and increases savings, as shown in the graph below. The savings start with machines that are designed to be easily installed. Your laundry can be up and running in hours instead of days.

Our machines are engineered with the finest components to ensure a longer lasting machine. Our inverter driven single motor design offers flexible operation, precise speed control and verified motor protection. Every component that comes into contact with the wash solution is 304 (18/8) Stainless Steel. The entire B&C Technologies line features our proven frame design, the strongest in the industry. The backbone of any machine is the frame and ours is designed and tested to stand the true rigorous demands of continuous operation in your laundry.

B&C Washer-Extractors: Reliable, Efficient, Affordable.

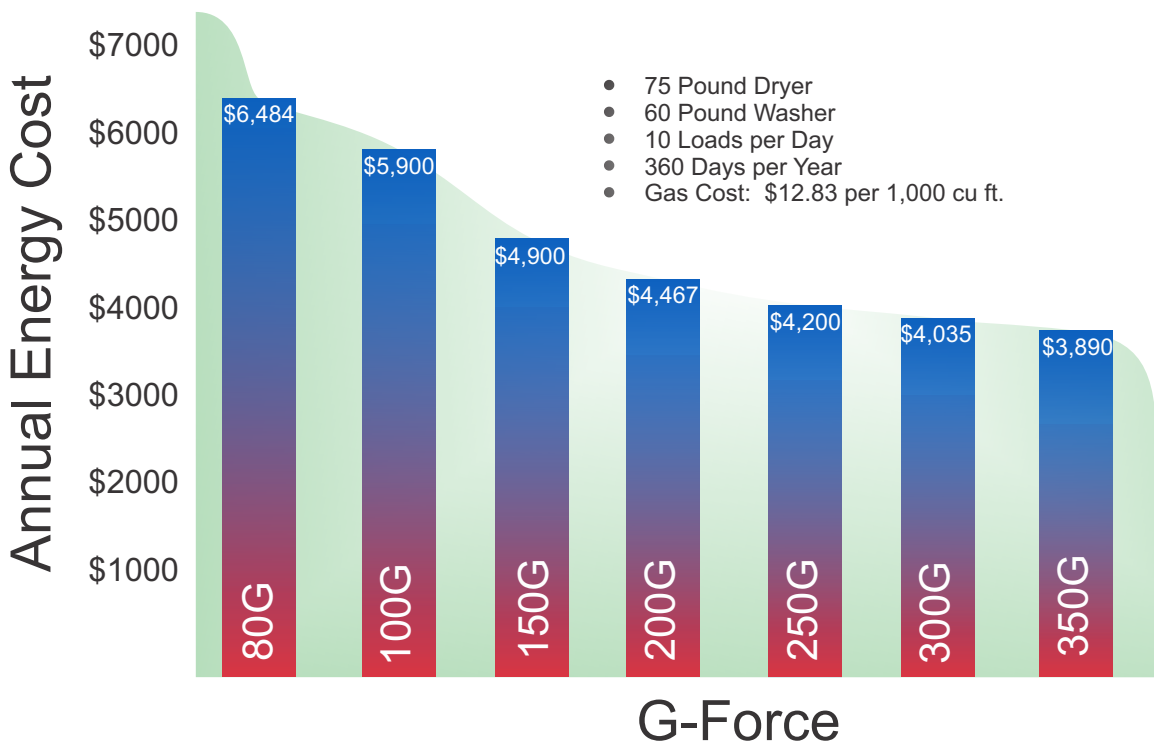

HE Series

Hardmount Medium Speed Economy Washer-Extractors for Small to Medium Sized General Laundry Applications, Including Health Care, Hospitality and Correctional Facilities.

Outstanding Reliability and Efficiency at an Affordable Price



The HE Series:

- ◆ 35, 45, 65, 85, and 110 pound capacities
- ◆ 200G extraction equals less time in the dryer
- ◆ Controls are simple to use and easy to program
- ◆ 4 compartment supply dispenser for liquid and dry chemicals
- ◆ 4 connections for automatic chemical injection
- ◆ Easily moved with a pallet jack while on or off of the skid
- ◆ Large door opening for easier loading and unloading
- ◆ Strong door and hinge system made of 304 stainless steel
- ◆ 5 degree lean back for lower bearing loads and less vibration

HE-65

MODEL	Units		HE-35		HE-45		HE-65		HE-85		HE-110	
	Metric	US										
CAPACITY:												
Dry Weight Capacity	kg	lbs	15.9	35.0	20.5	45.0	29.5	65.0	38.6	85.0	50.0	110.0
Cylinder Volume	liters	cu ft	128	4.5	187	6.6	274	9.7	372	13.1	467	16.5
OVERALL DIMENSIONS:												
A - Width	mm	in	737	29.0	787	31.0	879	34.6	1048	41.3	1048	41.3
B - Depth	mm	in	889	35.0	1092	43.0	1168	46.0	1219	48.0	1363	53.7
C - Height	mm	in	1276	50.3	1321	52.0	1530	60.3	1721	67.8	1721	67.8
D - Door Swing	mm	in	483	19.0	533	21.0	533	21.0	559	22.0	559	22.0
WEIGHT AND SHIPPING INFORMATION:												
Net Weight	kg	lbs	235	517	480	1055	660	1450	785	1728	958	2108
Domestic Shipping Weight	kg	lbs	246	543	492	1083	720	1584	803	1767	981	2160
ELECTRICAL SERVICE:												
208-240VAC, 50/60Hz, 1PH	Amps	Breaker	6.2	15	8.1	15	8.8	15	22	25	31	40
208-240VAC, 50/60Hz, 3PH	Amps	Breaker	3.6	15	4.7	15	5.1	15	12.7	15	18	20
380-480VAC, 50/60Hz, 3PH	Amps	Breaker	1.8	15	2.3	15	2.5	15	6.3	15	9	15

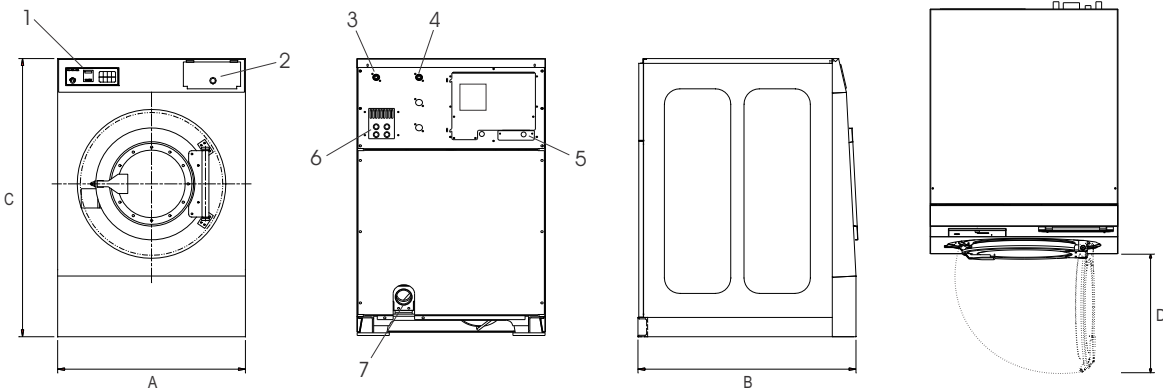

- Components:**
- 1 - Controls
 - 2 - Supply Dispenser
 - 3 - Hot Water
 - 4 - Cold Water
 - 5 - Electrical Connection
 - 6 - External Supply Connections
 - 7 - Drain Connection

HP Series

Hardmount High Speed Professional Washer-Extractors for General Laundry Applications, Including Health Care, Hospitality and Correctional Facilities.

Outstanding Reliability and Efficiency at an Affordable Price



HP-65

The HP Series:

- ◆ 65 or 125 pound capacity
- ◆ Up to 300G extraction equals less time in the dryer
- ◆ Powerful and easy to use control with unequaled flexibility
- ◆ 8 connections for automatic chemical injection
- ◆ HP-65 easily moved with a pallet jack while on or off of the skid
- ◆ Optional through the door spray rinsing system on HP-65
- ◆ Strong door and hinge system made of 304 stainless steel
- ◆ HP-65 features CARB bearing system for outstanding reliability
- ◆ HP-125 features industrial strength pillow block bearing system
- ◆ 5 degree lean back for lower bearing loads and less vibration

MODEL	Units		HP-65		HP-125	
	Metric	US				
CAPACITY:						
Dry Weight Capacity	kg	lbs	29.5	65.0	56.7	125.0
Cylinder Volume	liters	cu ft	274	9.7	567	19
OVERALL DIMENSIONS:						
A - Width	mm	in	879	34.6	1295	51.0
B - Depth	mm	in	1270	50.0	1554	61.2
C - Height	mm	in	1676	66.0	1669	65.7
D - Door Swing	mm	in	533	21.0	635	25.0
WEIGHT AND SHIPPING INFORMATION:						
Net Weight	kg	lbs	660	1450	1995	4390
Domestic shipping weight	kg	lbs	720	1584	2011	4425
ELECTRICAL SERVICE:						
208-240VAC, 50/60Hz, 1PH	Amps	Breaker	13.6	15	n/a	n/a
208-240VAC, 50/60Hz, 3PH	Amps	Breaker	8	15	32	40
380-480VAC, 50/60Hz, 3PH	Amps	Breaker	4	15	16	20

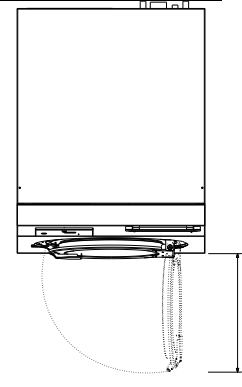
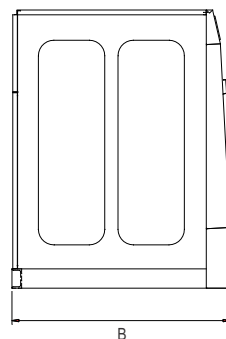
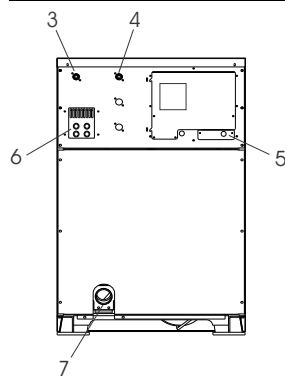
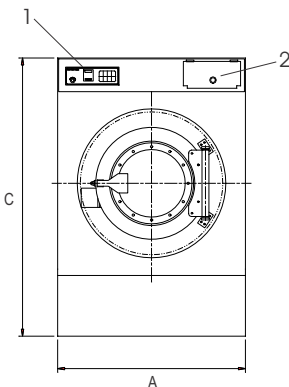

- Components:**
- 1 - Controls
 - 2 - Supply Dispenser
 - 3 - Hot Water
 - 4 - Cold Water
 - 5 - Electrical Connection
 - 6 - External Supply Connections
 - 7 - Drain Connection

SP Series

Softmount High Speed Professional Washer-Extractors for Medium Sized Heavy Duty On Premise Laundry Applications, Including Health Care, Hospitality, and Drycleaners / Wetcleaners

Outstanding Reliability and Efficiency at an Affordable Price



SP-65

The SP Series:

- ◆ 45, 50, 65, 75, 110, 135, 165, 195 pound capacities
- ◆ 350G extraction equals less time in the dryer
- ◆ Powerful and easy to use control with unequaled flexibility
- ◆ 1 compartment supply dispenser for liquid and dry chemicals
- ◆ 8 connections for automatic chemical injection
- ◆ Easily moved with a pallet jack while on or off of the skid
- ◆ Large door opening for easier loading and unloading
- ◆ Strong door and hinge system made of 304 stainless steel
- ◆ Revolutionary CARB bearing system for outstanding reliability
- ◆ 5 degree lean back for lower bearing loads and less vibration

MODEL	Metric	US	SP-45		SP-50		SP-65		SP-75		SP-110		SP-135		SP-165		SP-195	
CAPACITY:																		
Dry Weight Capacity	kg	lbs	20.5	45.0	22.7	50.0	29.6	65.0	34.1	75.0	50.0	110.0	61.4	135.0	75.0	165.0	88.7	195.0
Cylinder Volume	liters	cu ft	187.0	6.6	208.8	7.4	273.9	9.7	306.0	10.8	467.0	16.5	590.1	20.8	709.0	25.0	844.3	29.8
OVERALL DIMENSIONS																		
A - Width	mm	in	925	36.4	925	36.4	1003	39.5	1003	39.5	1204	47.4	1300	51.2	1538	60.6	1602	63.1
B - Depth	mm	in	1093	43.0	1153	45.4	1231	48.5	1306	51.4	1395	54.9	1600	63.0	1730	68.1	1784	70.2
C - Height	mm	in	1466	57.7	1466	57.7	1615	63.6	1615	63.6	1805	71.1	1765	69.5	1826	71.9	1894	74.6
D - Door Swing	mm	in	526	20.7	526	20.7	577	22.7	577	22.7	610	24.0	749	29.5	749	29.5	749	29.5
WEIGHT AND SHIPPING INFORMATION																		
Net Weight	kg	lb	591	1300.2	615	1353	660	1452	687	1511.4	1068	2349.6	1183	2602.6	1910	4202	2090	4598
Shipping Weight	kg	lb	610	1342	634	1394.8	720	1584	747	1643.4	1091	2400.2	1233	2712.6	1955	4301	2135	4697
ELECTRICAL SERVICE:																		
208-240VAC, 50/60HZ, 1PH	Amps	Breaker	8	15	9	15	14	15	15	20	31	40	n/a	n/a	n/a	n/a	n/a	n/a
208-240VAC, 50/60HZ, 3PH	Amps	Breaker	5	15	6	15	8	15	9	15	18	20	26	60	32	40	58	60
380-460VAC, 50/60HZ, 3PH	Amps	Breaker	3	15	3	15	4	15	4	15	9	15	13	20	16	25	29	30
208-240VAC, 50/60HZ, 3PH Elec. Heat	Amps	Breaker	48	60	49	60	52	60	53	60	78	80	n/a	n/a	n/a	n/a	n/a	n/a
380-460VAC, 50/60HZ, 3PH Elec. Heat	Amps	Breaker	24	30	25	30	26	30	27	30	39	40	n/a	n/a	n/a	n/a	n/a	n/a

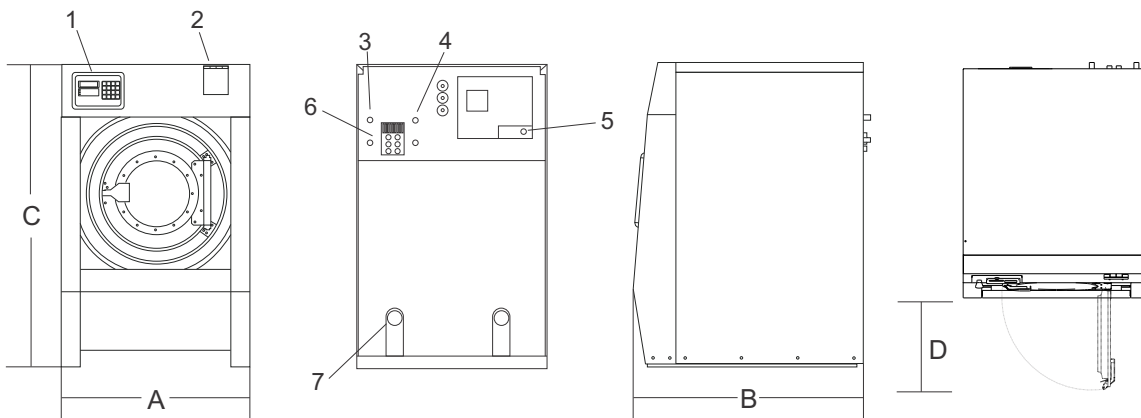

- Components:**
- 1 - Controls
 - 2 - Supply Dispenser
 - 3 - Hot Water
 - 4 - Cold Water
 - 5 - Electrical Connection
 - 6 - External Supply Connections
 - 7 - Drain Connection

SI Series

Softmount High Speed Industrial Strength Washer-Extractors for Medium to Large Sized On Premise Laundry, Commercial and Industrial Laundry Applications, Including Resort Hospitality, Health Care, and Correctional Facilities

Outstanding Reliability and Efficiency at an Affordable Price

The SI Series:



- ◆ 110, 135, 200, 275, and 300 pound capacities
- ◆ 320G extraction equals less time in the dryer
- ◆ Powerful and easy to use control with unequaled flexibility
- ◆ 5 compartment supply dispenser for liquid and dry chemicals
- ◆ 8 connections for automatic chemical injection
- ◆ Large door opening for easier loading and unloading
- ◆ Strong door and hinge system made of 304 stainless steel
- ◆ Dry zone bearings are not damaged should seals leak
- ◆ 3 degree lean back for lower bearing loads and less vibration

SI-275

MODEL	Metric	US	SI-110		SI-135		SI-200		SI-275		SI-300	
CAPACITY:												
Dry Weight Capacity	kg	lbs	50.0	110	61.4	135	90.9	200	125.0	275	136.4	300
Cylinder Volume	liters	cu ft	441	15.6	595	21	871	30.8	1184	41.8	1323	46.7
OVERALL DIMENSIONS												
A - Width (Add 10" for tilt)	mm	in	1395	55.75	1626	64	1708	67.25	1886	74.25	1886	74.25
B - Height (Add 3" for 1-way tilt, 5" for 2-way tilt)	mm	in	1734	68.25	1918	75.5	1975	77.75	2159	85	2159	85
C - Depth (Add 10" for tilt)	mm	in	1759	69.25	1810	71.25	2108	83	2248	88.5	2350	92.5
D - Tilted Height (1-way / 2-way)	mm	in	2190	86.2	2248	88.5	2595	102.2	2875	113.2	2875	113.2
			2266	89.2	2324	91.5	2671	105.2	2952	116.2	2952	116.2
WEIGHT AND SHIPPING INFORMATION												
Net Weight	kg	lb	2000	4400	2434	5355	3489	7675	4300	9460	4743	10435
Shipping Weight	kg	lb	2032	4470	2466	5425	3530	7765	4345	9560	4800	10560
ELECTRICAL SERVICE:												
208-240VAC, 50/60HZ, 3PH	Amps	Breaker	21	30	32	40	58	60	79	80	89	90
380-460VAC, 50/60HZ, 3PH	Amps	Breaker	11	15	16	20	29	30	39	40	45	50

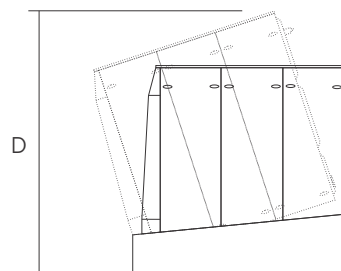
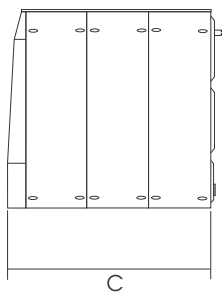
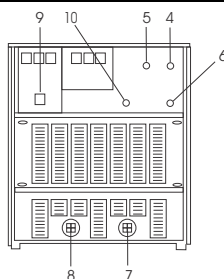
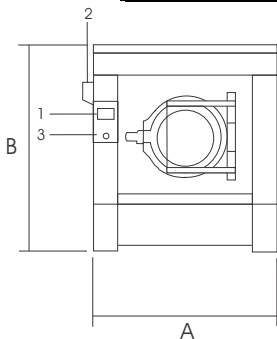

1. Microprocessor Controls
2. Supply Dispenser
3. Control Compartment
4. Hot Water Inlet
5. Cold Water Inlet
6. Steam Inlet
7. Reuse Drain (Optional)
8. Drain
9. Electrical Connection
10. Air Inlet

SA Series

Softmount High Speed Automatic Industrial Strength Washer-Extractors for Medium to Large Sized On Premise Laundry, Commercial and Industrial Laundry Applications, Including Resort Hospitality, Health Care, and Correctional Facilities

Outstanding Reliability and Efficiency at an Affordable Price



The SA Series:

- ◆ 275, 300, and 475 pound capacities
- ◆ 320G extraction equals less time in the dryer
- ◆ Powerful and easy to use control with unequaled flexibility
- ◆ Standard 2 way tilting
- ◆ Standard hydraulic assist door
- ◆ Dry zone bearings are not damaged should seals leak
- ◆ 40 inch door for easy loading and unloading
- ◆ Steam injection system
- ◆ 3 degree lean back for lower bearing loads and less vibration

SA-475

MODEL	Metric	US	SA-275		SA-300		SA-475	
CAPACITY:								
Dry Weight Capacity	kg	lbs	125.0	275	136.4	300	215.9	475
Cylinder Volume	liters	cu ft	1184	41.8	1323	46.7	2131	75.3
OVERALL DIMENSIONS								
A - Width	mm	in	2140	84.25	2140	84.25	2615	102.95
B - Height	mm	in	2286	90	2286	90	2540	100
C - Depth	mm	in	2502	98.5	2604	102.5	2270	89.37
D - Tilted Height	mm	in	2952	116.2	2952	116.2	3040	119.7
WEIGHT AND SHIPPING INFORMATION								
Net Weight	kg	lb	4300	9460	4743	10435	8636	19000
Shipping Weight	kg	lb	4345	9560	4800	10560	8825	19414
ELECTRICAL SERVICE:								
208-240VAC, 50/60HZ, 3PH	Amps	Breaker	79	80	89	90	95	150
380-460VAC, 50/60HZ, 3PH	Amps	Breaker	39	40	45	50	48	80

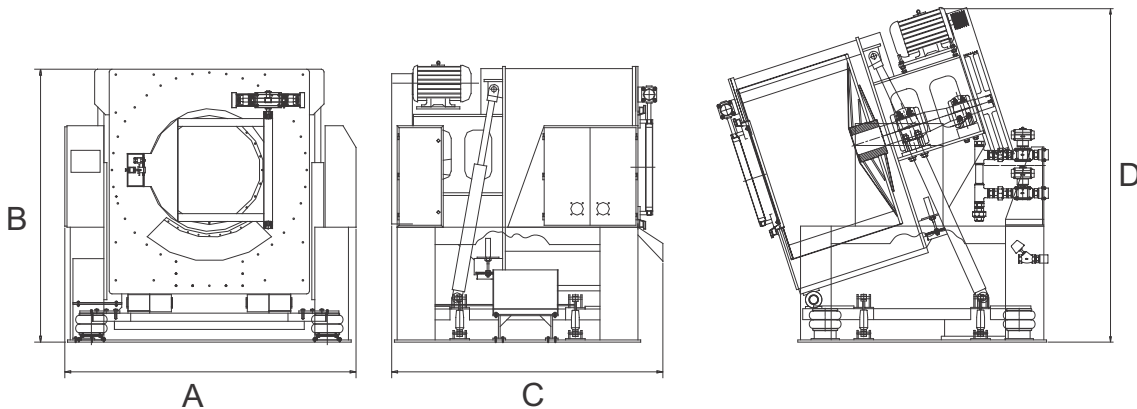

SB Series

Softmount Barrier Washer-Extractors for Small, Medium, and Large Sized On Premise Laundry Applications Where Hygiene is a Major Concern, Including Health Care and Clean Room Operations.

Outstanding Reliability and Efficiency at an Affordable Price

The SB Series:



- ◆ 60, 80, 155, 225, 300, and 485 pound capacities
- ◆ Designed to be built into the wall separating the clean and soiled sides of the facility
- ◆ 350G extraction equals less time in the dryer, yielding tremendous savings
- ◆ Powerful and easy to use control with unequaled flexibility
- ◆ SB-60 and SB-80 are open pocket
- ◆ SB-155, SB-225, and SB-300 are 3 pocket
- ◆ SB-485 is 6 pocket

SB-225

MODEL	Metric	US	SB-60		SB-80		SB-155		SB-225		SB-300		SB-485	
CAPACITY:														
Dry Weight Capacity	kg	lbs	27	60	37	80	71	155	102	225	136	300	220	485
Cylinder Volume	liters	cu ft	270	9.5	365	13.1	705	25.0	1023	36.5	1363	48.0	2203	77.7
OVERALL DIMENSIONS														
A - Width	mm	in	1305	51.4	1492	58.7	1615	63.6	1973	77.7	2325	91.5	2585	101.8
B - Depth	mm	in	1279	50.4	1279	50.4	1596	62.8	1596	62.8	1765	69.5	2155	84.8
C - Height	mm	in	1681	66.2	1681	66.2	2124	83.6	2124	83.6	2120	83.5	2625	103.3
D - Door Swing	mm	in	425	16.7	515	20.3	600	23.6	705	27.8	760	29.9	1160	45.7
WEIGHT AND SHIPPING INFORMATION														
Net Weight	kg	lb	1250	2750	1560	3432	2476	5447	2794	6147	3630	7986	4540	9988
Shipping Weight	kg	lb	1270	2794	1580	3476	2500	5500	2820	6204	3658	8048	4568	10050
ELECTRICAL SERVICE:														
208-240VAC, 50/60HZ, 1PH	Amps	Breaker	14	15	31	40	n/a	n/a	n/a	n/a	n/a	n/a	n/a	n/a
208-240VAC, 50/60HZ, 3PH	Amps	Breaker	8	15	18	20	32	40	58	60	89	90	95	150
380-460VAC, 50/60HZ, 3PH	Amps	Breaker	4	15	9	15	16	25	29	30	45	50	48	80

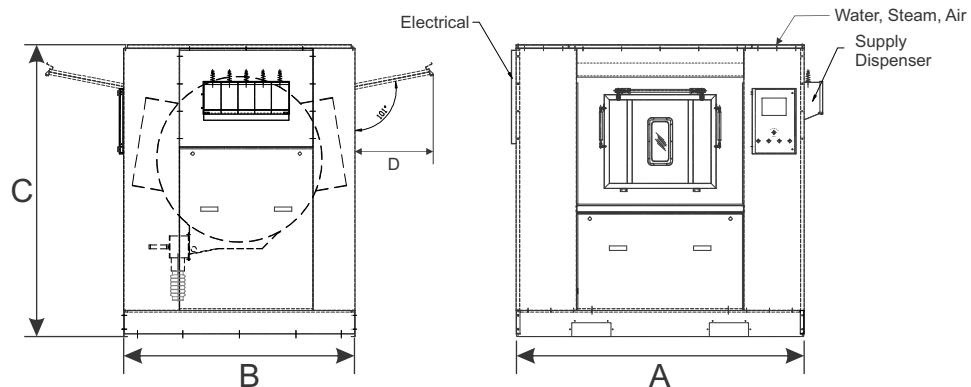

Water Washing / Wetcleaning From B&C Technologies



SP-65

SP Series Washer (45,50,65,75,110,135,165,195 lb capacity)



Complete flexibility in your laundry. The SP Series allows you to go from standard laundry to wet cleaning in the same machine. There is no need to invest in a special wet clean only machine. The EL6 control allows finely programmable water levels, temperatures, agitation times, and extremely slow wash speeds that will not damage delicate articles.

DE Series Dryer (30,50,75,120,170,190 lb capacity)



Overdrying can damage or shrink fabrics; a moisture sensor minimizes that possibility. B&C Technologies dryers equipped with the optional moisture sensor can save an additional 15% on energy costs over standard timed drying. The B&C system precisely measures the remaining water left in the goods and stops the drying process when they are dry. This saves time, money, and wear.

- Less wear and tear on goods
- Lower energy costs
- More loads per week
- Automatically adjusts to different sized loads
- Excellent for wetcleaning



DE-75

TS-93 Cabinet Dryer, 32lb drying capacity

TS-63 Cabinet Dryer, 20lb drying capacity



Where does all the lint come from? Many modern garments include a do not tumble dry label on the tag. Tumble drying is an efficient drying process, but it prematurely wears the clothes through friction and mechanical action. A B&C Technologies drying cabinet is the perfect solution for drying water washed goods. Drying cabinets dry the goods without any mechanical action allowing for virtually no wear and tear on the goods. Humidity Tracking System (HTS) plus programmable time and temperature ensure perfect results. Large internal racks allow for maximum capacity.



TS-63

BioSpin Ozone System From B&C Technologies

The savings at B&C continue with our ozone system. The BioSpin Ozone system offers benefits through less chemical usage, less hot water usage, shorter cycle times and improved life of linens. Ozone is a bleaching and sanitizing agent that leaves lightly soiled laundry fresh and sanitized using a simple wash process that doesn't use hot water. Since there is no chlorine bleach used in ozone wash programs, rinsing and souring are minimized and only a small amount of pH neutral detergent. Process times, hot water, and chemical usage can be greatly reduced.

BioSpin and B&C Technologies: Environmentally and Economically Sound.



MODEL	Units		CLS-60		CLS-120		CLS-250		CLS-500	
	US	Metric								
Flow Rate										
Average Ozonated Water Flow Rate @ > 2.0ppm	GPM	LPH	1.98	450	3.96	900	7.92	1800	15.84	3600
Maximum Output Flow Rate	GPM	LPH	17.6	4000	4000	17.6	4000	17.6	22	5000
Washer Extractor Sizing										
Hospitality Capacity Suitability (total capacity)	lbs	kg	65.00	29.55	130.00	59.09	275.00	125.00	550.00	250.00
Health Care Capacity Suitability (total capacity)	lbs	kg	35.00	15.91	65.00	29.55	125.00	56.82	275.00	125.00
Dimensions										
Width	in	mm	20.47	520	24.80	630	24.80	630	16.54	420
Depth	in	mm	9.45	240	15.87	403	15.87	403	39.37	1000
Height	in	mm	19.69	500	35.43	900	35.43	900	35.43	900
Water Input and Output Connection										
Fresh Water Inlet			NPT		3/4		3/4		3/4	
Ozonated Water Outlet			NPT		1/2		1/2		3/4	
Electrical Requirements										
120VAC, 60Hz, 1PH	Watts		900		950		1050		1100	
Weight and Shipping Information										
Net Weight	lbs	kg	70	32	85	39	100	45	150	68
Shipping Weight	lbs	kg	75	34	90	41	110	50	163	74

How the system works:

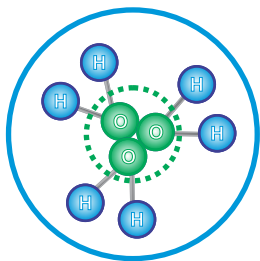

1. The BioSpin Electrolytic Ozone Generator creates high purity ozone directly from water.

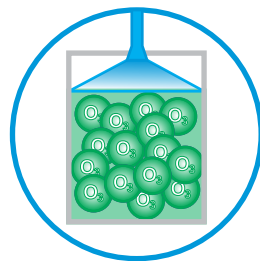

2. High purity ozone is dissolved into the water using a patented mixing pump to create ultra concentrated ozonated water.

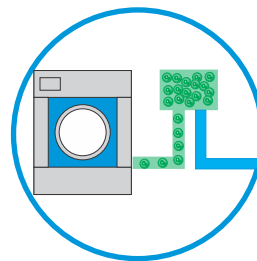

3. Ultra concentrated ozonated water is mixed with cold tap water and fed into the washing machine.

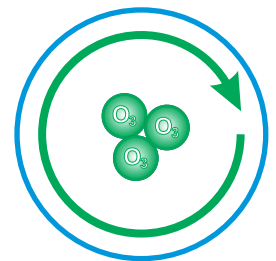

4. Ozone is replenished between wash fills and stored for use in the next wash cycle.

The Dryer Line From B&C Technologies

Outstanding Reliability and Efficiency at an Affordable Price

To complement our line of superior washer-extractors, B&C Technologies offers the most rugged dryers in the industry. A low initial investment is only the beginning of your savings. All B&C dryers are manufactured with fewer parts which means fewer break downs, less downtime and less maintenance. Easy installation saves you money and time so you can have your laundry up and running in a matter of hours. Engineered and manufactured with installation in mind, these sturdy dryers use welded steel cabinets and heavy duty steel bases that can be easily moved without damaging the machine.

The B&C line features an energy saving, fully enclosed, insulated cabinet. This leads to much quieter operation as well as keeping the heat in the dryer where it belongs. High airflow rates and high BTU burners dry the goods quickly for increased productivity in the laundry.

Our durable drive system is built to last. Fan cooled motors, cast iron pulleys, plus a standard stainless steel drying cylinder make the B&C line of dryers the best value in the industry.

Never waste time and money over drying your goods again. Humidity sensing is available on all machines that are equipped with the microprocessor control.

Even the doors are designed for ease of use and long life. Doors swing open 180 degrees for increased accessibility. Maintenance on the B&C dryer door is reduced by our service free magnetic latch. You'll find exactly what fits your drying needs.

The B&C Dryer Line: Efficient, Affordable, Rugged.

The B&C Technologies humidity sensing system measures the moisture in the exhaust as it leaves the dryer. Our system uses a sensor which is mounted in the exhaust duct of the dryer to measure the moisture left in the goods. It is a simple, reliable, and accurate way to measure remaining moisture, prevent over drying, and prevent damage to delicate goods or handle special processes like wet cleaning. Unlike our competitors, the B&C system is accurate and repeatable, saving time and money in your laundry.



DE Series

Economy High Efficiency Dryers for General Laundry Applications and Small to Medium Sized On Premise Laundries Including Hotel/Motel, Healthcare, Athletics, and Drycleaners.

Outstanding Reliability and Efficiency at an Affordable Price



The DE Series:

- ◆ 30, 50, 75, 120, 170, and 190 pound capacities
- ◆ Standard dual timer control, microprocessor optional
- ◆ Steam, gas, or electric heat provides smooth and even heat
- ◆ Easy to clean lint compartment
- ◆ Standard reversing cylinder on DE-120, DE-170 and DE-190
- ◆ Steam damper system on DE-120, DE-170 and DE-190
- ◆ Advanced corrosion resistant coating
- ◆ Easy to maintain
- ◆ Stainless steel drying cylinder standard

DE-75

MODEL	Metric	US	DE-30		DE-50		DE-75		DE-120		DE-170		DE-190	
CAPACITY:														
Dry Weight Capacity	kg	lbs	13.6	30.0	22.7	50.0	34.1	75.0	54.5	120.0	77.3	170.0	86.4	190.0
Cylinder Volume	liters	cu ft	347	12.3	509	18.0	601	21.5	1080	38.1	1451	51.2	1587	56.0
OVERALL DIMENSIONS:														
A - Width	mm	in	800	31.5	984	38.8	984	38.8	1200	47.3	1429	56.3	1429	56.3
B - Depth	mm	in	1067	42.0	1086	42.8	1213	47.8	1600	63.0	1689	66.5	1791	70.5
C - Height (max)	mm	in	1854	73.0	1943	76.5	1943	76.5	2280	89.8	2534	99.8	2534	99.8
D - Door Swing	mm	in	705	27.8	806	31.8	806	31.8	984	38.8	1060	41.8	1060	41.8
WEIGHT AND SHIPPING INFORMATION:														
Net Weight	kg	lbs	305	670	368	810	402	885	750	1650	1000	2200	1227	2700
Domestic shipping weight	kg	lbs	327	720	386	850	414	910	773	1700	1045	2300	1273	2800
ELECTRICAL SERVICE:														
110-120VAC, 50/60Hz, 1PH	Amps	Breaker	10	20	12	20	14	20	n/a	n/a	n/a	n/a	n/a	n/a
208-240VAC, 50/60Hz, 1PH	Amps	Breaker	13	15	14	15	21	25	n/a	n/a	n/a	n/a	n/a	n/a
208-240VAC, 50/60Hz, 3PH	Amps	Breaker	5	15	6	15	9	15	23	30	32	40	36	40
380-480VAC, 50/60Hz, 3PH	Amps	Breaker	1.4	15	3.5	15	4.5	15	11	15	16	20	18	20
208-240VAC, 50/60Hz, 3PH, ELEC HT	Amps	Breaker	60	70	60	70	98	100	196	200	n/a	n/a	n/a	n/a
380-480VAC, 50/60Hz, 3PH, ELEC HT	Amps	Breaker	30	40	30	40	32	45	97	100	n/a	n/a	n/a	n/a

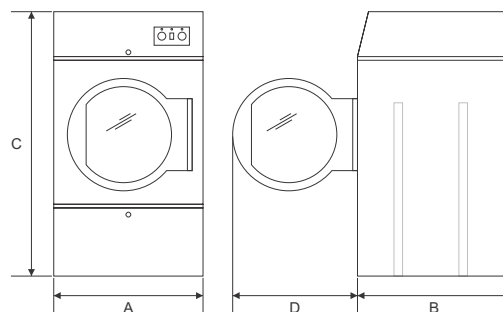

DP Series

Professional High Efficiency Dryers for General Laundry Applications and Medium Sized On Premise Laundries Including Hotel/Motel, Healthcare, Athletics, and Drycleaning Plants.

Outstanding Reliability and Efficiency at an Affordable Price



DP-200

The DP Series:

- ◆ 200 and 250 pound capacities
- ◆ Optional tilt to unload
- ◆ Large easy to clean lint drawer
- ◆ Stainless steel drying cylinder standard
- ◆ Steam or gas heating
- ◆ Steam damper system
- ◆ Reversing cylinder standard
- ◆ Microprocessor control

MODEL	Metric	US	DP-200		DP-250	
CAPACITY:						
Dry Weight Capacity	kg	lbs	90.9	200.0	113.6	250.0
Cylinder Volume	liters	cu ft	2123	75.0	2180	77.0
OVERALL DIMENSIONS:						
A - Width	mm	in	1651	65.0	1651	65.0
B - Depth	mm	in	2012	79.2	2134	84.0
C - Height (Steam)	mm	in	2372	93.4	2372	93.4
D - Height (Gas)	mm	in	2565	101.0	2565	101.0
E - Door Swing	mm	in	978	38.5	978	38.5
F - Tilted Height	mm	in	2953	116.3	2953	116.3
WEIGHT AND SHIPPING INFORMATION:						
Net Weight	kg	lbs	1152	2535	1311	2885
Domestic shipping weight	kg	lbs	1168	2570	1327	2920
ELECTRICAL SERVICE:						
208-240VAC, 50/60Hz, 3PH	Amps	Breaker	34	80	39	80
380-480VAC, 50/60Hz, 3PH	Amps	Breaker	16	40	40	80

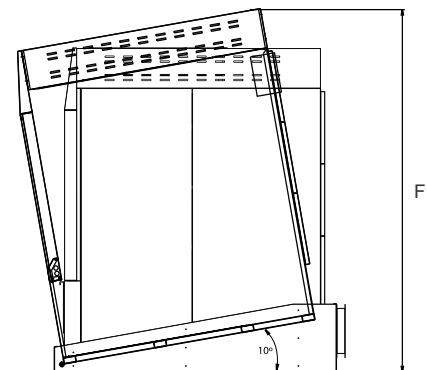
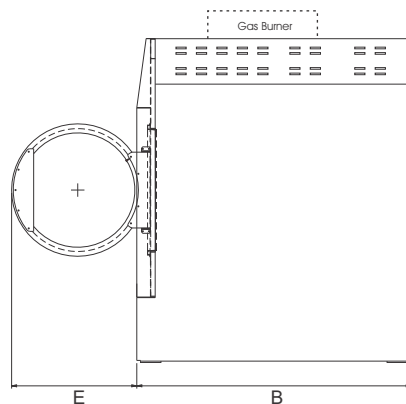
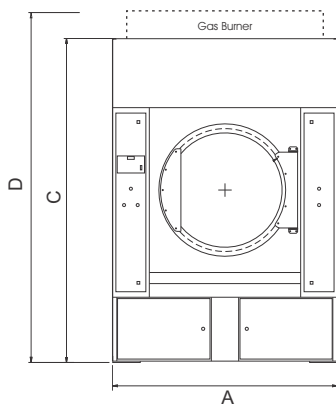

DI Series

Industrial High Efficiency Dryers for General Laundry Applications and Large Sized On Premise Laundries Including Hotel/Motel, Healthcare, Athletics, and Drycleaning Plants.

Outstanding Reliability and Efficiency at an Affordable Price



The DI Series:

- ◆ 225, 325, and 475 pound capacities
- ◆ Many custom options to suit the installation
- ◆ Optional 1 or 2 way tilting
- ◆ Vertical or Horizontal opening doors
- ◆ Pass through with rear chute
- ◆ Microprocessor control
- ◆ Tunnel system integration available
- ◆ Steam, atmospheric gas, or forced air burner (standard on 475)

DI-225

MODEL	Metric	US	DI-225		DI-325		DI-475	
CAPACITY:								
Dry Weight Capacity	kg	lbs	102.3	225.0	147.7	325.0	215.9	475.0
Cylinder Volume	liters	cu ft	2550	90.3	3170	112.2	5100	180.1
OVERALL DIMENSIONS:								
A - Width	mm	in	1926	75.8	1976	77.8	3007	118.4
B - Depth	mm	in	1534	60.4	1851	72.9	2322	91.4
C - Height	mm	in	3025	119.1	3107	122.3	3033	119.4
D - Tilted Height	mm	in	3220	126.8	3358	132.2	3498	137.7
WEIGHT AND SHIPPING INFORMATION:								
Net Weight	kg	lbs	2727	6000	3182	7000	3959	8710
Domestic shipping weight	kg	lbs	2818	6200	3273	7200	4045	8900
ELECTRICAL SERVICE:								
208-240VAC, 50/60Hz, 3PH	Amps	Breaker	62	100	87	125	90	125
380-480VAC, 50/60Hz, 3PH	Amps	Breaker	31	50	43	60	45	60

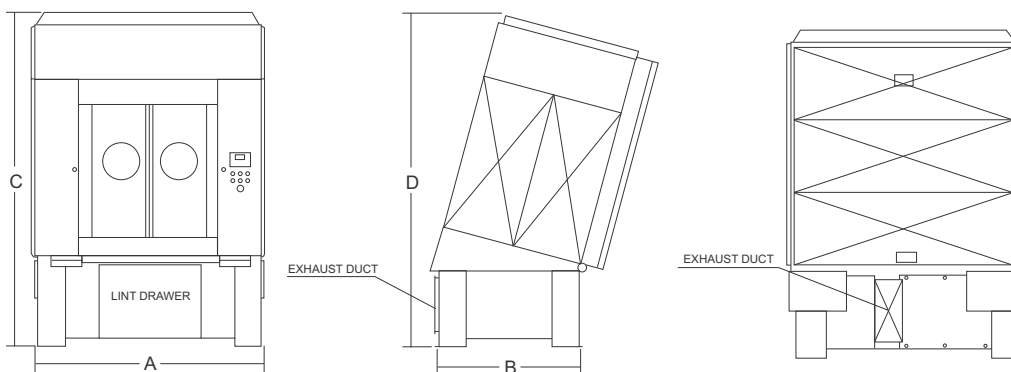

The Drying Cabinet Line From B&C Technologies

Modern design and efficiency at an affordable price

Europeans have been using drying cabinets for over fifty years both professionally and domestically as a complement to standard tumbling clothes dryers. Now available in the Americas, drying cabinets are proving to be indispensable for goods that can not be traditionally dried.

The drying cabinet dries efficiently without mechanical action at exactly the right temperature and humidity. Studies show that 20-30% of garments worn daily should not be tumble dried as many show a do not tumble symbol on the care label. A drying cabinet is ideal for articles not suitable for tumble dryers as well as special processes like wetcleaning. Gentle drying action leads directly to longer fabric life, as the goods are not tumbling against each other or against the drying cylinder.

Drying cabinets have a much longer life span than conventional tumble dryers due to very few moving parts. B&C drying cabinets feature sturdy construction and excellent engineering which leads to extended machine life. New controls and fan systems have made the cabinets highly energy efficient, creating lower energy costs.

Flat packaging saves shipping costs and reduces shipping damage. Manual or automatic drying modes with accurate temperature sensing and our unique humidity tracking system (HTS) prevents over drying and saves energy. Underpressure drying technology creates a partial vacuum by utilizing three fans which speeds drying time and lowers energy costs.

B&C Technologies has an exceptional line of professional drying cabinets designed for many different markets and custom marketplaces. The combination of decades of experience and our new technology makes our drying cabinets an excellent alternative and complement to tumble dryers.



TS-63

Medium Sized Drying Cabinet for Efficient Hang Drying of Delicate Garments that should not be Tumble Dried. Perfect for Drycleaners, Wetcleaners, Theaters, Ski Resorts, Daycare Centers and more.

Outstanding Reliability and Efficiency at an Affordable Price



TS-63

The TS-63:

- ◆ 20 pound capacity
- ◆ Swing out hanging rails with 50 feet of hanging length
- ◆ Optional single hanging bar
- ◆ High temperature programs, up to 195°F, greatly reduce bacterial contaminants and allergens
- ◆ Electric heating
- ◆ Microprocessor control with manual and automatic modes

MODEL	Metric	US	TS-63	
CAPACITY:				
	kg	lbs	9.1	20.0
OVERALL DIMENSIONS:				
A - Width	mm	in	1200	47.2
B - Depth	mm	in	640	25.2
C - Height	mm	in	1870	73.6
D - Rack Swing, Front	mm	in	812	32.0
E - Door Swing	mm	in	487	19.2
F - Rack Swing, Side	mm	in	695	27.4
WEIGHT AND SHIPPING INFORMATION:				
Net Weight	kg	lbs	145	319
Domestic shipping weight	kg	lbs	152	334
ELECTRICAL SERVICE:				
208-240VAC, 50/60Hz, 1PH	Amps	Breaker	35	40
208-240VAC, 50/60Hz, 3PH	Amps	Breaker	22	30
380-480VAC, 50/60Hz, 3PH	Amps	Breaker	12	15

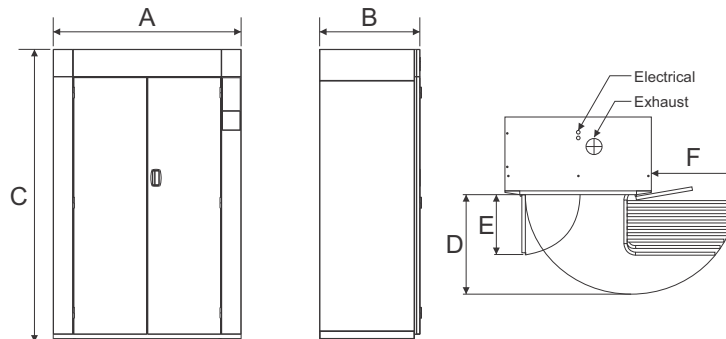

TS-93

Large Sized Drying Cabinet for Efficient Hang Drying of Delicate Garments that should not be Tumble Dried. Perfect for Drycleaners, Wetcleaners, Theaters, Ski Resorts, Healthcare and more.

Outstanding Reliability and Efficiency at an Affordable Price

The TS-93:

- ◆ 32 pound capacity
- ◆ Swing out hanging rails with 90 feet of hanging length
- ◆ Optional single hanging bar
- ◆ High temperature programs, up to 195°F, greatly reduce bacterial contaminants and allergens
- ◆ Electric heating
- ◆ Microprocessor control with manual and automatic modes



TS-93

MODEL	Metric	US	TS-93	
CAPACITY:				
	kg	lb	14.5	32.0
OVERALL DIMENSIONS:				
A - Width	mm	in	1800	70.9
B - Depth	mm	in	800	31.5
C - Height	mm	in	1955	77.0
D - Rack Swing, Front	mm	in	1392	54.8
E - Door Swing	mm	in	788	31.0
WEIGHT AND SHIPPING INFORMATION:				
Net Weight	kg	lb	200	440
Domestic shipping weight	kg	lb	212	466
ELECTRICAL SERVICE:				
208-240VAC, 50/60Hz, 1PH	Amps	Breaker	65	70
208-240VAC, 50/60Hz, 3PH	Amps	Breaker	35	40
380-480VAC, 50/60Hz, 3PH	Amps	Breaker	17	20

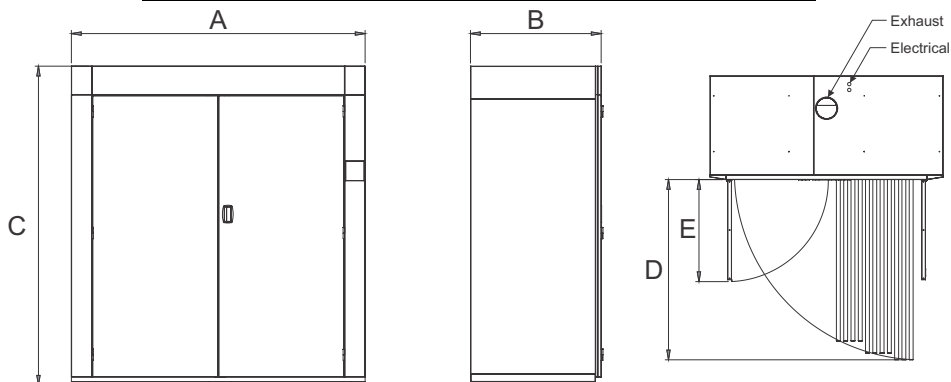

FC-20

Large Sized Drying Cabinet for Efficient Hang Drying of Firehouse Turnout Gear and Protective Overalls, Gloves, Boots, Masks, and other Station Wear as well as Wet Suits and Dry Suits.

Outstanding Reliability and Efficiency at an Affordable Price

The FC-20:

- ◆ Dries 6 sets of turnout gear
- ◆ Specially designed for drying heavy duty overalls
- ◆ 6 ventilated hangers that help dry from the inside
- ◆ Meets National Fire Protection Association (NFPA) standards
- ◆ 9 available drying programs
- ◆ Extends the life of zippers and protective tape
- ◆ Optional hangers for boots and gloves



FC-20

MODEL	Metric	US	FC-20	
CAPACITY:				
	kg	lbs	14.5	32.0
OVERALL DIMENSIONS:				
A - Width	mm	in	1800	70.9
B - Depth	mm	in	800	31.5
C - Height	mm	in	1955	77.0
D - Door Swing	mm	in	788	31.0
WEIGHT AND SHIPPING INFORMATION:				
Net Weight	kg	lbs	200	440
Domestic shipping weight	kg	lbs	212	466
ELECTRICAL SERVICE:				
208-240VAC, 50/60Hz, 1PH	Amps	Breaker	65	70
208-240VAC, 50/60Hz, 3PH	Amps	Breaker	35	40
380-480VAC, 50/60Hz, 3PH	Amps	Breaker	17	20

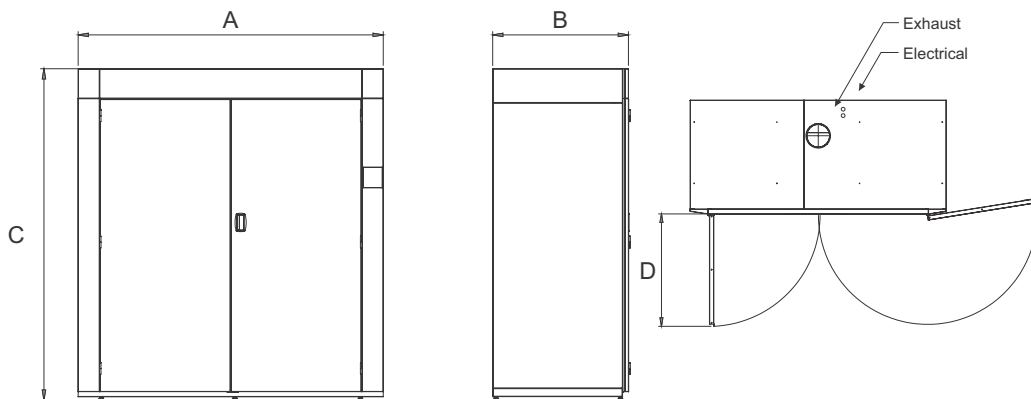

The Ironer Line From B&C Technologies

Outstanding Reliability and Efficiency at an Affordable Price

The B&C line of ironers provides you with outstanding performance at the lowest price. Increased efficiency, fewer parts, and low maintenance help save you money.

The robust, energy efficient inverter drive system allows for incredibly flexible operation and excellent protection for the motor. By using the latest technology our drive system provides precise speed control and soft starting which reduces stress on critical components.

Our easy to use controls are designed to provide accurate temperature regulation and can be adjusted at any time.

Nomex padding and belts are long lasting and impervious to the high temperatures found in the ironing environment. The heavy duty steel frame gives our ironer strength and durability.

The operator's safety is of utmost importance. We ensure a safe to use machine by utilizing industry standard safety features such as circuit protection, emergency stops located around the machine and interlocked panels.

The B&C Ironer Line: Powerful, Dependable, Affordable.

There is no substitute for the luxurious appearance and feel that crisply ironed table linens, napkins, pillowcases, and sheets provide. Ironed linens convey a message of first class quality and cleanliness. Linens that are only tumble dried give the impression of previous use by an earlier guest.



IP Series

Compact Economy Ironers for Small to Medium Sized General Laundry Applications Demanding High Standards of Linen Quality. Perfect for Hotels, Health Care, and Party Rental.

Outstanding Reliability and Efficiency at an Affordable Price

The IP Series:



- ◆ 78, 85, and 100 inch working width, 14 inch diameter roll
- ◆ Steam, gas, or electric heating
- ◆ Chrome plated ironing cylinder - waxing not required
- ◆ Digital temperature and speed controls
- ◆ Jog forward/reverse
- ◆ Full exhaust canopy with external blower
- ◆ Perfect for napkins, pillowcases, and more
- ◆ Goods return to operator

IP-1478

MODEL	Metric	US	IP-1478		IP-1485		IP-14100	
NUMBER OF ROLLS			1		1		1	
Roll Diameter	mm	inch	355.6	14	355.6	14	355.6	14
Working Width	mm	inch	2000	78	2159	85	2540	100
DIMENSIONS								
A - Width	mm	inch	2502	98.5	2680	105.5	3061	120.5
B - Depth	mm	inch	715	28.2	715	28.2	715	28.2
C - Height	mm	inch	1744	68.7	1744	68.7	1744	68.7
D - Canopy Height	mm	inch	434	17	434	17	434	17
WEIGHT AND SHIPPING								
Net Weight	kg	lbs	477	1051	520	1144	600	1320
Shipping Weight	kg	lbs	527	1162	570	1254	650	1430
ELECTRICAL SERVICE:								
208-240VAC, 50/60Hz, 1PH	Amps	Breaker	10	15	10	15	10	15
208-240VAC, 50/60Hz, 3PH	Amps	Breaker	3	15	5	15	3	15
380-480VAC, 50/60Hz, 3PH	Amps	Breaker	2	15	3	15	2	15
208-240VAC, 50/60Hz, 3PH ELEC HT	Amps	Breaker	31	40	31	40	31	40
380-480VAC, 50/60Hz, 3PH ELEC HT	Amps	Breaker	26	30	26	30	26	30

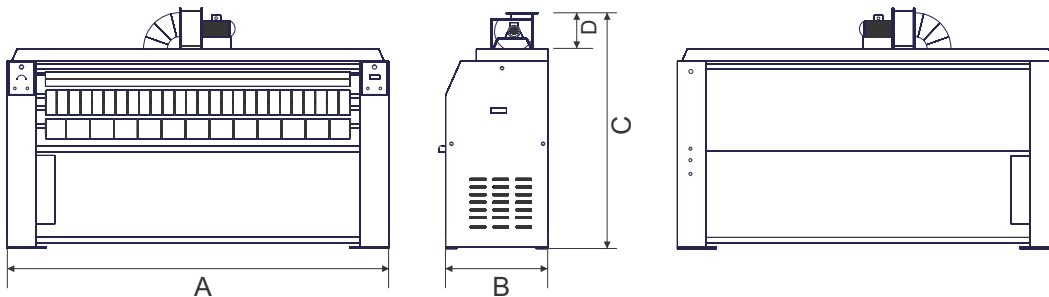

IS Series

Single Roll High Performance Ironers for Small/Medium Sized On Premise Laundries Demanding High Quality Linen Service. Perfect for Hotels, Resort Hospitality, and Party Rental.

Outstanding Reliability and Efficiency at an Affordable Price

The IS Series:

- ◆ 14, 18, 24, or 32 inch diameter roll. 120 inch working width
- ◆ Steam or gas heating
- ◆ Chrome plated ironing cylinder - waxing not required
- ◆ Digital temperature and speed controls
- ◆ Jog forward/reverse
- ◆ Full exhaust canopy with external blower
- ◆ Perfect for napkins, pillowcases, table linens, sheets, and more
- ◆ Switchable return, front to operator or rear return.



IS-18120

MODEL	Metric		US		IS-14120		IS-18120		IS-24120		IS-32120	
	mm	inch	mm	inch	mm	inch	mm	inch	mm	inch	mm	inch
NUMBER OF ROLLS			1		1		1		1		1	
Roll Diameter	mm	inch	355.6	14	457.2	18	609.6	24	812.8	32		
Working Width	mm	inch	3048	120	3048	120	3048	120	3048	120		
DIMENSIONS												
A - Width	mm	inch	4059	159.8	4059	159.8	4059	159.8	4059	159.8		
B - Depth	mm	inch	826	32.5	1501	59.1	1593	62.7	1593	62.7		
C - Height	mm	inch	2140	84.25	2504	98.6	2443	96.2	2483	97.75		
D - Canopy Height	mm	inch	464	18.25	658	25.9	625	24.6	464	18.25		
WEIGHT AND SHIPPING												
Net Weight	kg	lbs	1182	2600	2000	4400	2823	6210	2909	6400		
Shipping Weight	kg	lbs	1293	2844	2045	4500	2868	6310	2955	6500		
ELECTRICAL SERVICE:												
208-240VAC, 50/60Hz, 3PH	Amps	Breaker	8	15	10	15	12	15	16	20		
380-480VAC, 50/60Hz, 3PH	Amps	Breaker	4	15	5	15	6	15	8	15		

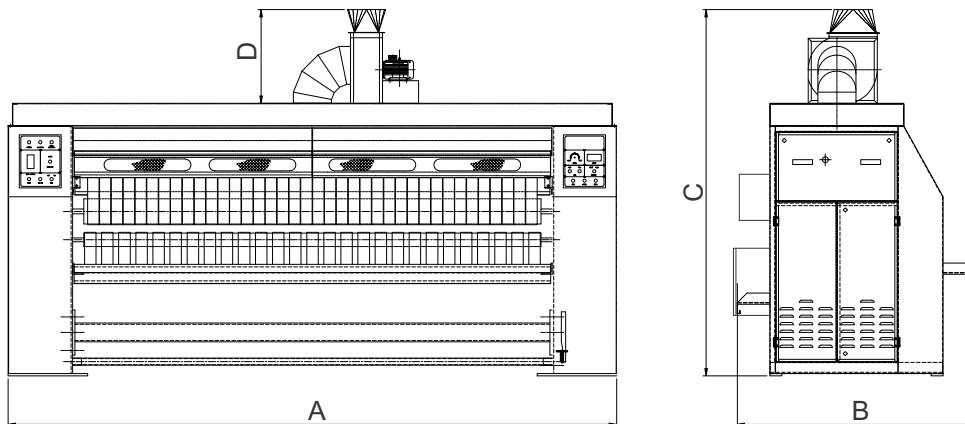

IQ Series

Single Roll High Performance Ironers for Medium Sized On Premise Laundries Demanding High Quality Linen Service. Perfect for Hotels, Resort Hospitality, and Party Rental.

Outstanding Reliability and Efficiency at an Affordable Price

The IQ Series:



- ◆ 24, 32, or 40 inch diameter roll. 130 inch working width
- ◆ Steam, gas, or electric heating
- ◆ Optional primary folder
- ◆ Optional feeder
- ◆ Easy to use controls
- ◆ Nomex padding and belts
- ◆ Built in exhaust
- ◆ Heavy duty frame
- ◆ Fully enclosed for heat retention
- ◆ Goods return to the operator or rear return (optional)

IQ-32130

MODEL	Metric	US	IQ-24130		IQ-32130		IQ-40130	
NUMBER OF ROLLS			1		1		1	
Roll Diameter	mm	inch	600	24	800	32	1000	40
Working Width	mm	inch	3300	130	3300	130	3300	130
DIMENSIONS								
A - Width	mm	inch	4374	172.2	4486	176.6	4598	181.0
B - Depth	mm	inch	1500	59.1	1827	71.9	2154	84.8
C - Height	mm	inch	1800	70.9	1977	77.8	2154	84.8
WEIGHT AND SHIPPING								
Net Weight	kg	lbs	2850	6270	3350	7370	3850	8470
Shipping Weight	kg	lbs	2900	6380	3400	7480	3900	8580
ELECTRICAL SERVICE:								
208-240VAC, 50/60Hz, 3PH	Amps	Breaker	12	15	16	20	20	25
380-480VAC, 50/60Hz, 3PH	Amps	Breaker	6	15	8	15	10	15

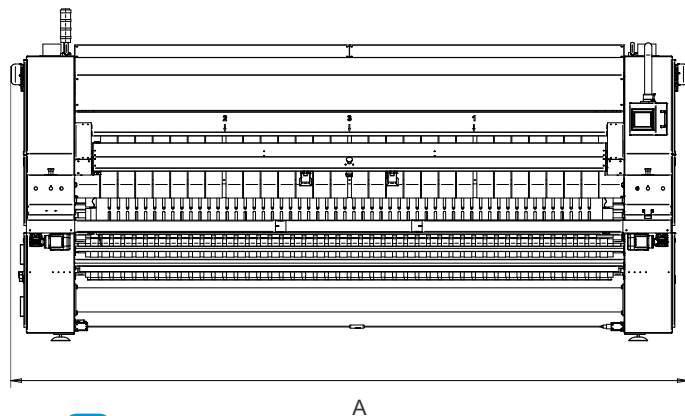
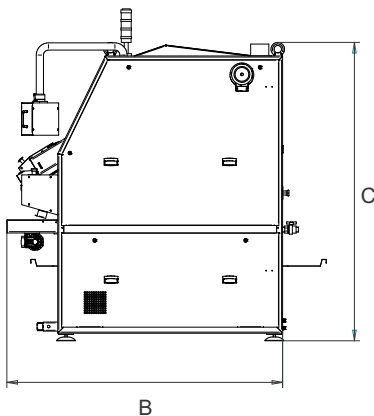

IF Series

Single Roll High Performance Ironers with Integrated Feeder and Folder for Medium Sized On Premise Laundries Demanding High Quality Linen Service. Perfect for Hotels and Resort Hospitality.

Outstanding Reliability and Efficiency at an Affordable Price

The IF Series:

- ◆ 24 or 32 inch diameter roll
- ◆ 126 inch working width
- ◆ All in one convenience
- ◆ Steam or gas heating
- ◆ Digital temperature and speed controls
- ◆ Over 300 pounds per hour when using high speed B&C washers
- ◆ Takes up less than 10 square meters / 110 square feet



IF-32126

MODEL			IF-24126		IF-32126	
	Metric	US				
NUMBER OF ROLLS			1		1	
Roll Diameter	mm	inch	600	24	800	32
Working Width	mm	inch	3200	126	3200	126
DIMENSIONS						
A - Width	mm	inch	5530	217.7	5590	220.1
B - Depth	mm	inch	2715	106.9	2860	112.6
C - Height	mm	inch	2135	84.1	2335	91.9
WEIGHT AND SHIPPING						
Net Weight	kg	lbs	3250	7150	4000	8800
Shipping Weight	kg	lbs	3350	7370	4100	9020
ELECTRICAL SERVICE:						
208-240VAC, 50/60Hz, 3PH	Amps	Breaker	24	30	26	30
380-480VAC, 50/60Hz, 3PH	Amps	Breaker	14	20	16	20

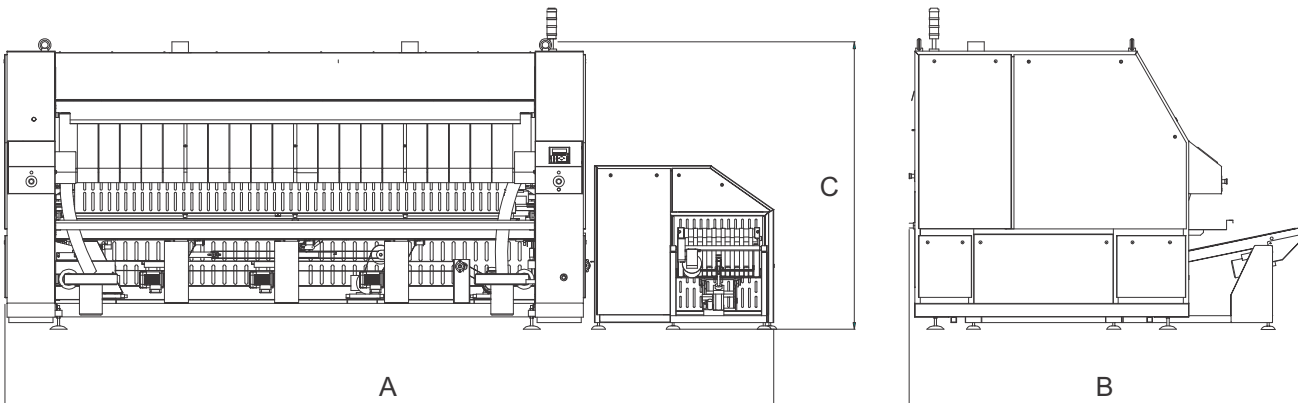

IM Series

Multi Roll High Productivity Deep Chest Ironers for Large Sized On Premise Laundries Demanding High Quality Linen Service. Perfect for Industrial, Health Care, and Hospital Laundries.

Outstanding Reliability and Efficiency at an Affordable Price

The IM Series:

- ◆ 32 or 48 inch diameter rolls
- ◆ Working widths up to 4000mm (158 inches)
- ◆ 1, 2, 3, or 4 rolls for tremendous production capabilities
- ◆ Steam, thermal fluid, or self-contained thermal fluid heating
- ◆ Highly polished chests
- ◆ Springpress springs for outstanding results and life
- ◆ Rolls lock when up for safety
- ◆ Independent roll suction fans
- ◆ Can be integrated with any feeder or folder



IM-12302

MODEL	Metric	US	IM-800				IM-1200			
			3000X1		3000X2		3000X1		3000X2	
NUMBER OF ROLLS			1		2		1		2	
Roll Diameter	mm	in	800	31.5	800	31.5	1200	47.2	1200	47.2
Working Width	mm	in	3000	118.1	3000	118.1	3000	118.1	3000	118.1
Speed Range	m/min	ft/min	6 - 20	20 - 66	4 - 38	13 - 125	6 - 25	20 - 82	5 - 50	16 - 164
OVERALL DIMENSIONS										
A - Width	mm	in	4290	168.9	4290	168.9	4450	175.2	4450	175.2
B - Depth	mm	in	2528	99.5	3668	144.4	2813	110.8	4429	183.0
C - Height	mm	in	1780	70.0	1780	70.0	1888	74.3	1888	74.3
WEIGHT AND SHIPPING INFORMATION										
Net Weight	kg	lbs	2844	6257	5688	12514	3640	8008	7280	16016
Domestic shipping weight	kg	lbs	3044	6697	5938	13064	3920	8624	7630	16786
ELECTRICAL SERVICE										
208-240VAC, 50/60Hz, 3PH (Steam)	Amps	Breaker	17	30	32	40	23	30	44	50
380-480VAC, 50/60Hz, 3PH (Steam)	Amps	Breaker	8	20	16	30	11	20	22	30
208-240VAC, 50/60Hz, 3PH (Oil)	Amps	Breaker	54	60	69	80	60	70	81	90
380-480VAC, 50/60Hz, 3PH (Oil)	Amps	Breaker	27	40	35	50	30	40	41	50

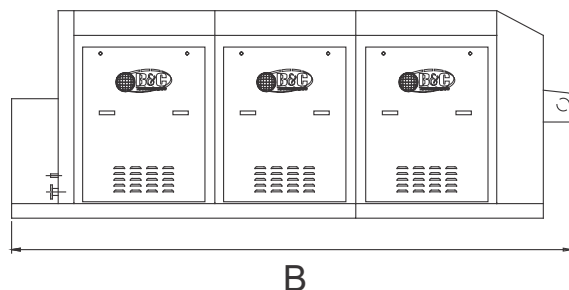
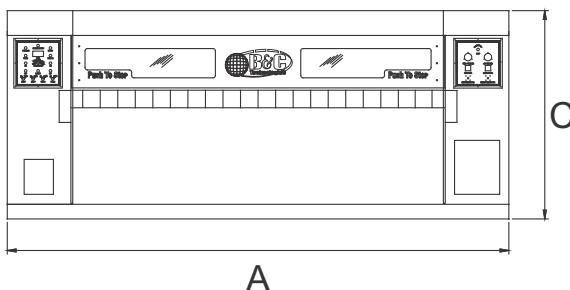

The Feeding and Folding Lines From B&C Technologies

Modern Design and Efficiency at an Affordable Price

B&C Technologies is there for your laundry needs from beginning to end. We take you step by step starting with our line of economical, high efficiency washers, then to our powerful line of dryers and drying cabinets, on to our unsurpassed single roll and multi roll deep chest ironers and finally to our dependable feeders and folders. Using only the highest quality components, our finishing equipment is designed to produce outstanding results and long life. We designed our machines with simplicity in mind, keeping our equipment user friendly and easy to maintain. This allows for savings of both training time and repair costs. We know there are varying demands of laundries - that is why our feeders and folders offer versatility. Our ergonomic, user friendly design allows for stress free operation. The incredible speed of our line of folders allow you to increase your productivity while maintaining high quality output. Folding equipment from B&C Technologies gives your goods a perfect finishing touch.



PF Series

Small Piece Precision Folder that Folds, Sorts, and Stacks a Wide Variety of Small Goods Including Towels, Hospital Gowns, Garments and Other Flat Goods.

Outstanding Reliability and Efficiency at an Affordable Price

The PF Series:

- ◆ Folds with air blasts or optional knives
- ◆ Optionally sorts and stacks according to size
- ◆ Automatically adjusts for different widths
- ◆ Optional conveyor system
- ◆ French folds with one, two, or no crossfold
- ◆ Can fold all goods the same width via programming
- ◆ Wheels for easy mobility
- ◆ 100 available programs



PF-3

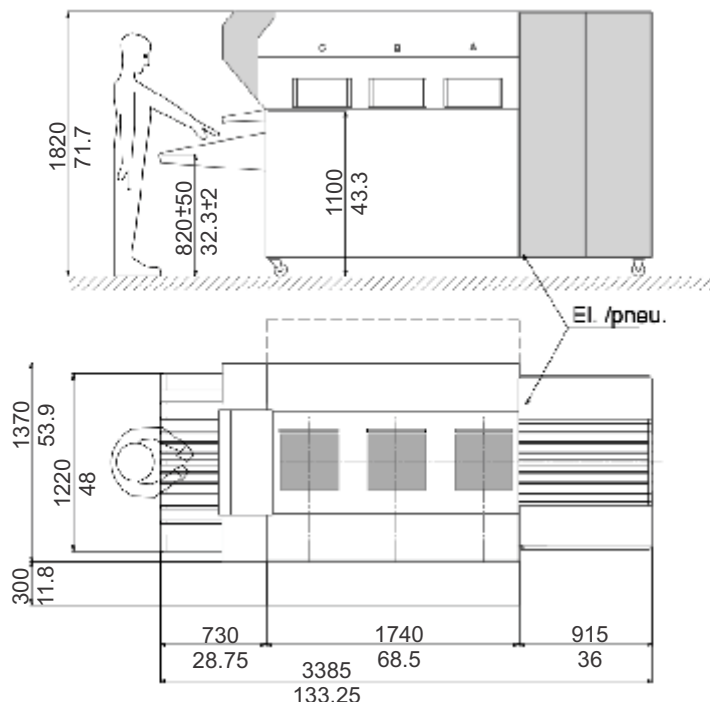

Technical Specifications:

Electrical Connection:

230V, 3ph, 60Hz, 15A breaker
460V, 3ph, 60Hz, 15A breaker

Pneumatic Connection:

100 psi / 7 bar
1/2" / 13mm connection
4 CFM / 6 cubic meters/hr

Weight:

2800 lbs
1280 kg

PS Series

Precision Sheet Folding In One, Two, or Four Lanes with or without Crossfolding for Precise Folding of Sheets and other Goods from an Ironer.

Outstanding Reliability and Efficiency at an Affordable Price

The PS Series:



- ◆ 1, 2, or 4 lanes available
- ◆ Optional Stacker
- ◆ Inverter driven
- ◆ Static bar
- ◆ 2 primary folds and 3 crossfolds
- ◆ Self centering crossfold plate
- ◆ Powerful control with built in diagnostics
- ◆ Simple and elegant design

PSX-2 with stacker

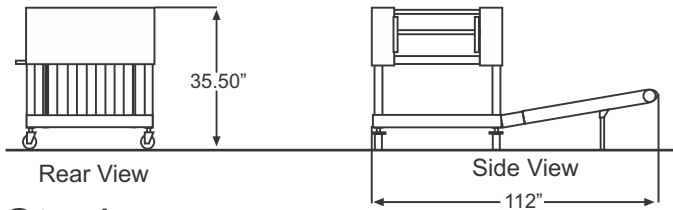

Stacker

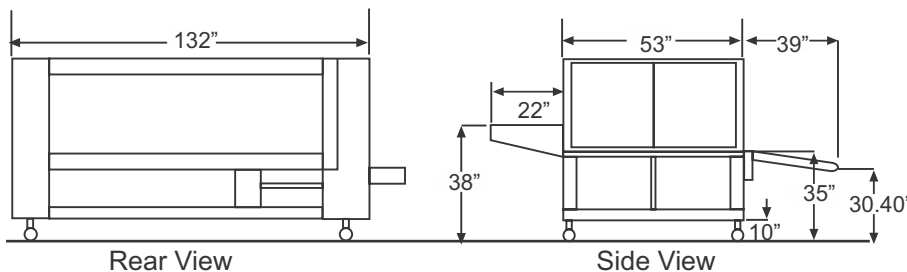

Folder

Technical Specifications:

Electrical Connection:

230V, 3ph, 60Hz, 15A breaker
460V, 3ph, 60Hz, 15A breaker

Pneumatic Connection:

100 psi / 7 bar
1/2" / 13mm connection
5 CFM / 8.5 cubic meters/hr
8 CFM / 13 cubic meters/hr

Weight:

2800 lbs
1280 kg

Product Testimonials

B&C Technologies

"Our SI-275 is absolutely the best machine we have. I wish I had more of them to replace all of my existing machines. Thank you so much!"

Sal McGhee
Owner
Service Stars



"We used B&C Technologies in this hotel because we think that the technology is first class, world class. We think that B&C Technologies was the answer to what we have in our hotel as far as laundry systems are concerned."

Ali Meghji
Renaissance Hotel
Edmonton International Airport



"The equipment is a solid, cost effective and hassle free solution for our laundry needs and it stood the test of time; the last ten years we've had good performance out of the equipment for the people that have to use it every day."

Brooke Christianson
Vice President
Canalta Hotels



"Our B&C washers, dryers and ironer have given us many years of trouble-free operation and are strong and cost effective. As our laundry business has grown, we have added more B&C machines and now process only with B&C"

Vladimir Smoliakov - General Manager
System Laundry Management





Industries Served

No matter what industry you're in we have your laundry solution. Whether it's Healthcare, Fire Station, Hospitality, Agriculture, or Commercial Laundries, B&C Technologies has a line to suit any laundry need. We supply everything from washing machines to finishing equipment, for the smallest laundry to the largest. Since we provide the largest range of laundry equipment from a single supplier, you no longer have to go from place to place to equip your facility. We also offer laundry design services to help you build the most successful laundry possible. You can rely on B&C Technologies to be there every step of the way.





Service and Hospitality

Busy hotels don't have time for breakdowns. That's why we designed our machines to be trouble free. At B&C we know that fewer parts mean less things to wear out. Using less parts will reduce down time while increasing productivity. We also understand the need to save every dollar possible. Utilizing a higher G-force extraction leads to less time your goods need to spend in the dryer therefore lowering both energy and labor costs. Our machines are made to be user friendly. Easy to operate controls keep training time to a minimum so you can spend your time taking care of your guests. To complement each B&C washer-extractor, we have a rugged, economical dryer. Built with the same standards of quality and affordability, you can count on our dryers to keep your laundry running smoothly. Our complete line of finishing equipment makes your hotel and restaurant linens wrinkle free and truly finished.

You'll sleep well knowing we're taking care of the laundry.



HE-65

The HE Series:

- ◆ 35, 45, 65, 85, and 110 pound capacities
- ◆ 200G extraction equals less time in the dryer
- ◆ Large door opening for easier loading and unloading

The DE Series:

- ◆ 30, 50, 75, 120, 170, and 190 pound capacities
- ◆ Easy to maintain
- ◆ Stainless steel drying cylinder standard



DE-75



Firehouse

The clothes may not make the man, but a firefighter has to rely on his. Properly cleaned and dried turnout gear is critical for a firefighter. We want to help keep you safe with our line of washers and drying cabinets. We want you to know that your gear is as clean as possible without damage so all our Firehouse machines meet NFPA guidelines. Once your gear is clean it must be dried correctly and completely. The B&C drying cabinet protects your gear by using our patented humidity tracking system (HTS) to stop the drying process once the gear is completely dry. This ensures your gear is thoroughly dried while preventing unnecessary wear.

While you're working hard to protect others, you can rest easy knowing we're protecting you.

The HE Series:

- ◆ 35, 45, 65, 85, and 110 pound capacities
- ◆ 100G extraction meets NFPA standards
- ◆ Large door opening for easier loading and unloading

FC-20 Drying Cabinet:

- ◆ Dries 6 sets of turnout gear, boots, gloves and masks
- ◆ Specially designed for drying heavy duty overalls
- ◆ 6 ventilated hangers that help dry from the inside
- ◆ Meets NFPA standards



HE-65 Firehouse



FC-20



Healthcare

When you're busy caring for others you can't worry about how clean your laundry is. That's why we're here. B&C Technologies uses state of the technology to ensure that your laundry exceeds standards. Our barrier machines make it possible to keep soiled goods completely separated from clean. This will prevent blood born pathogens and other impurities from contaminating your clean laundry keeping your patients and you safer. Available BioSpin Ozone kills 99.9999% of bacteria and viruses, greatly reducing the possibility of infection from supposedly clean linens.

Let us take care of your laundry, you take care of your patients.

The SB Series:

- ◆ 60, 80, 155, 225, 300, and 485 pound capacities
- ◆ 350G extraction equals less time in the dryer
- ◆ Strong door and hinge system made of 304 stainless steel

The DI Series:

- ◆ 225, 325, and 475 pound capacities
- ◆ Optional 1 or 2 way tilting
- ◆ Vertical or Horizontal opening doors
- ◆ Pass through with rear chute



SB-225



DI-225



Dairy and Agriculture

The demands of a dairy farm can be tough. You need a washer that's just as tough. B&C washers are designed for demanding laundry applications. We utilize a solidly constructed frame to ensure our machines are sturdy and long lasting. Our line of washer-extractors will be able to keep with the busiest of farms. You can count on a B&C machine to get udder cloths clean and virtually dry so you don't have to slow down. Our softmount machines require virtually no foundation work so they can be placed where conventional hard mounts can't.

We think you'll agree - our machines are the cream of the crop.

The SP Series:

- ◆ 45, 50, 65, 75, 110, 135, 165, and 195 pound capacities
- ◆ 350G extraction - udder cloths can be used without drying
- ◆ Powerful easy to use control with unequaled flexibility
- ◆ 1 compartment supply dispenser for liquid and dry chemicals
- ◆ 8 connections for automatic chemical injection
- ◆ Easily moved with a pallet jack while on or off of the skid
- ◆ Large door opening for easier loading and unloading
- ◆ Strong door and hinge system made of 304 stainless steel
- ◆ Revolutionary CARB bearing system for outstanding reliability



SP-65

Athletics

Your team spills blood, sweat, and tears on the field, but you don't want it on their uniforms. B&C has that part covered. Our line of equipment will make sure your team looks their best when it's game time. We understand the high demands that sports uniforms place on laundry and we have machines that can meet those demands. Whether it's uniforms or towels we can have your laundry clean and fresh while saving you time and money. Our machines extract more water from the goods so they spend less time in the dryer and can have you back on the field sooner.

You cover the offense, we'll cover the laundry.



SP-65

The SP Series:

- ◆ 45, 50, 65, 75, 110, 135, 165, and 195 pound capacities
- ◆ 350G extraction equals less time in the dryer
- ◆ Large door opening for easier loading and unloading

The DE Series:

- ◆ 30, 50, 75, 120, 170, and 190 pound capacities
- ◆ Easy to maintain
- ◆ Stainless steel drying cylinder standard



DE-75



Drycleaning

Whether it's cotton or cashmere we can supply you with a line of equipment that gets clothes clean while saving money and time. Our line of high speed extract softmount machines can allow you skip the dryer with some goods. When you take a shirt out of a B&C machine it has the perfect moisture content to go straight from the washer to the press without conditioning. This allows you to save both money and time. For those cases when you do need a dryer we have a drying line to complement our high quality washers. Both are designed to be long lasting with few breakdowns. You don't have to worry about down time with our lines. Equipment from B&C will allow you get your customers clothes clean fast and do it economically. If you're considering wetcleaning, you won't need a separate machine as the B&C washer / dryer combination has you covered.

You make your customers look good, we'll make you look good.



SP-65

The SP Series:

- ◆ 45, 50, 65, 75, 110, 135, 165, and 195 pound capacities
- ◆ 350G extraction equals less time in the dryer
- ◆ Large door opening for easier loading and unloading

The DE Series:

- ◆ 30, 50, 75, 120, 170, and 190 pound capacities
- ◆ Easy to maintain
- ◆ Stainless steel drying cylinder standard



DE-75



Commercial Laundry

It's hard enough for most people to keep up with the demands of the family laundry. Families count their laundry by loads; you count yours by pounds. Most people can't comprehend having that amount of laundry to clean each day. We do. We also know that you don't have time to waste with machines that are down. All of our machines are designed to be simple to operate, long lasting, and economical. We designed our complete line to withstand the rigorous demands of a commercial laundry. We will be with you every step of the way. From our line of hard working washers, to our line of industrious dryers and finally our line of incomparable finishing equipment you can be assured that the processed goods will be clean and fresh.

A load in our machine is a load off your mind.





Industrial Laundry

It takes a lot of work to put out the amount of laundry an industrial laundry produces. You need machines that will work just as hard. At B&C we have a complete line to take you from the time you collect to the time you deliver. You no longer have to visit several vendors to equip your laundry. Our line of industrial washers are designed to help you increase productivity while lowering costs. High extract speeds lead to less dryer time and fewer parts lead to less downtime. This saves money on electricity, repair bills and keeps your laundry running faster. Our line of dryers and finishing equipment are designed with the same high standards as our washers. The economical to own, durable and efficient B&C equipment keeps up with the demands of continuous operation.

When you have a job that has rugged demands you need machines that are just as rugged.





Carwash

Our durable machines are built to withstand the rigors of the harsher environment present at a car wash. In addition to the rugged design, with a B&C washer you can save money on cleaning supplies. We offer the ability to impregnate cleaning cloths

with glass cleaner or many other cleaners so you no longer have to carry around spray bottles. No more wasted time refilling empty spray bottles, no more spills, no more lost bottles.

The easy to use machine saves you valuable time. Just put the towels in, select your program and press the start button. Your towels come out dry enough to use and your cleaning cloths are ready for action. This allows you to process more cars every day.

B&C Technologies - driving the savings to you.



SP-45

The SP Series:

- ◆ 350G extraction means no drying needed
- ◆ Large door opening for easier loading and unloading

The HE Series:

- ◆ 200G extraction leaves towels slightly moist
- ◆ Large door opening for easier loading and unloading



HE-35



Accounting and Office

The B&C accounting team has blended personal service with expertise to better care for our customers. Our skilled team works closely together to make sure B&C Technologies runs smoothly. Whether you have a question about accounts payable or receivable you can count on us to handle your request quickly and courteously. Order information, shipping quotes, and general information about B&C are a quick phone call or email away.

You'll always hear a friendly voice when you call B&C Technologies.



**Catharina
Whitehead**

cwhitehead@bandctech.com



**Debby
Garwood**

dgarwood@bandctech.com



**Carolyn
Davis**

cdavis@bandctech.com



**Marislea
Smith**

reception@bandctech.com



Engineering

B&C Technologies has put together a team of engineers that have vast experience in the laundry industry. All of our designs are engineering driven to maintain the highest standards and latest advances. The B&C Technologies engineering department was tantamount in the design of several different brands of machines that are still in use today. This wide range of experience make us ideal to help you find the machines that suit your laundry needs. Our expansive equipment line allows us to provide one stop shopping for all your laundry equipment needs. It doesn't end there. We offer laundry design services to help you easily get from the planning stage to a completed laundry quickly. Best of all, our customers have access to our engineers and can call to speak directly to us to get the help you need.



**Mats
Bruce**

mbruce@bandctech.com



**Chris
Oswald**

coswald@bandctech.com



**David
Whitehead**

dwhitehead@bandctech.com



**Paul
Noblit**

pnoblit@bandctech.com



**Shannon
Brown**

sbrown@bandctech.com



Parts and Service

We know parts wear out. We also know you want the best parts at the best price. At B&C we take that one step further and offer parts for most brands of machines giving you one place to find most anything you need.

Whether you need maintenance tips to keep your B&C equipment in top shape or advice when troubleshooting, our trained team of technicians are a phone call away. Our customers are our highest priority and we strive to ensure that we are here to help.

We encourage you to call our service department before you buy. You'll see just how easy we are to reach:

B&C Technical Service, 850-249-2222, weekdays 8 a.m. - 5 p.m. Central Time.



**Flip
Clemmons**

fclemmons@bandctech.com



**Trampas
Smith**

tsmith@bandctech.com



**Marvin
Rice**

mrice@bandctech.com



**Jimmy
Nelson**

jnelson@bandctech.com



**Larry
Harrison**

lharrison@bandctech.com

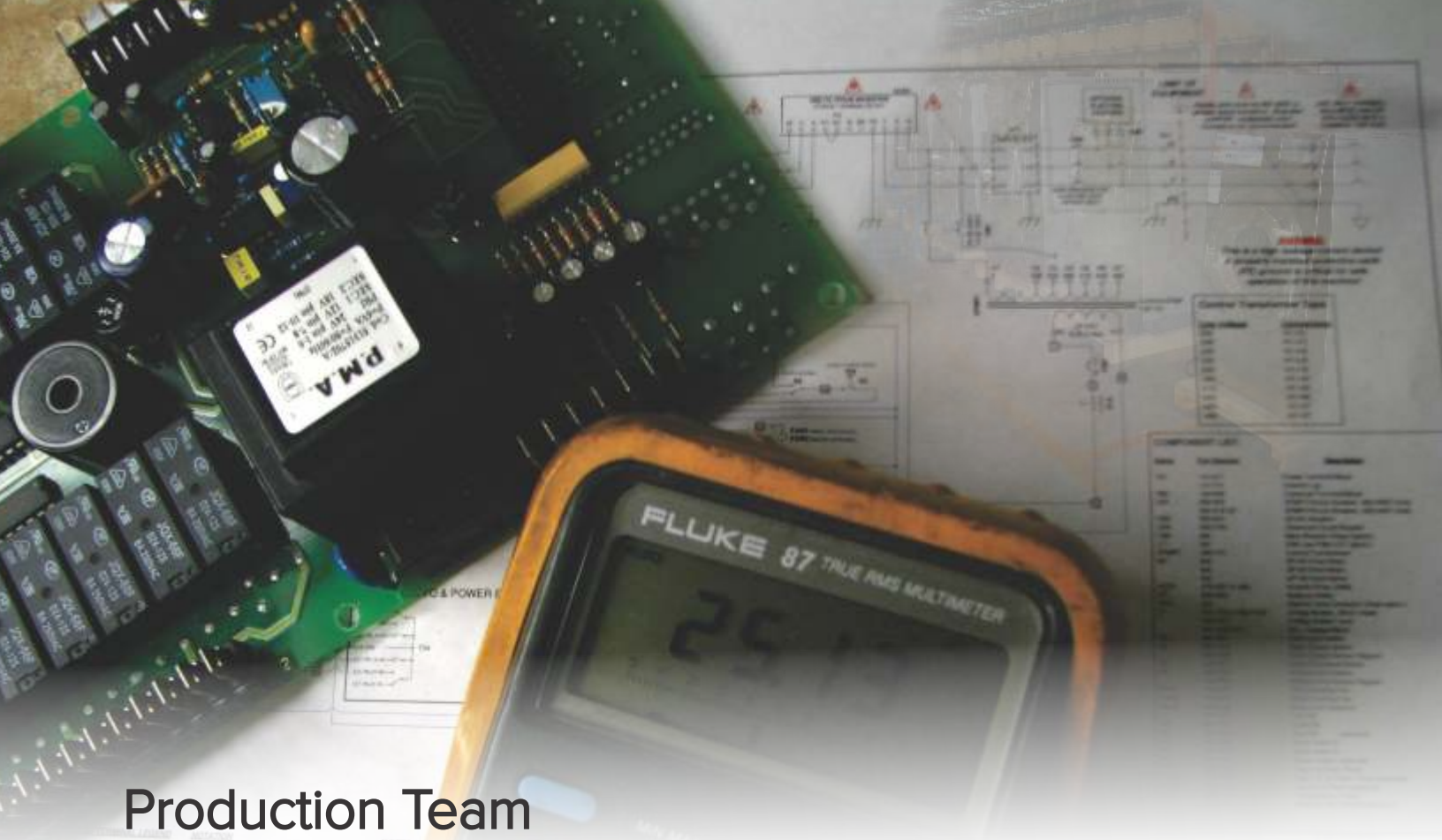

Production Team

The production team at B&C is responsible for every machine from the time it is ordered to when it leaves our warehouse. Before any machine is shipped out our team members perform full operational testing to make sure it meets our high quality standards. Each member of our team makes sure that quality is built into every stage of the process in order to ensure that waste is minimized and quality is maximized.

You can trust this group of trained professionals to ensure that your order gets personal attention and care.



**David
Whitehead**

dwhitehead@bandctech.com



**Jeff
Brewer**

jbrewer@bandctech.com

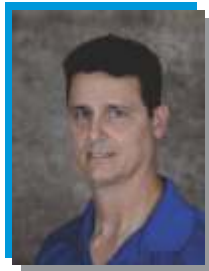

**Mike
Sweigert**

msweigert@bandctech.com



**Tom
Yokel**

tyokel@bandctech.com



**Justin
Dybdal**

jdybdal@bandctech.com



Sales & Marketing

Our sales and marketing team focuses on giving individualized attention to every customer. Our accomplished team has the skills necessary to engage our customers, reach out to clients, and offer the assistance and sales tools needed to our distributors. We work hard to make sure that you will have the best experience possible when you partner with B&C Technologies.

You can count on us to help in the bidding process from specifications all the way through to installation. In addition, we provide assistance and design service for marketing and advertising to help your business reach its full potential.



**Bengt
Bruce**

bbruce@bandctech.com



**Al
Adcock**

aadcock@bandctech.com

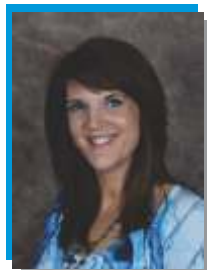

**Tracey
Adcock**

tadcock@bandctech.com



**Sonny
Myers**

smyers@bandctech.com



At B&C Technologies we are focused on providing the finest and most comprehensive line of laundry equipment available at the industry's best price. We back that with the most extensive parts department, easily accessible technical support and unparalleled customer service. We strive to make sure our company offers personal care and we will never have that corporate feeling.

We are the B&C family and we're glad to have you.

[Handwritten signatures]
Bob Lowers
Darryl Conner
Molly Lowers
C. Whitehead
M. [unclear]



Much more information is available on our website:
www.bandctech.com
Specifications subject to change without notice
©2015, B&C Technologies, LLC
All Rights Reserved